



SUBMITTAL : ECO-200SW18 200 Gallon & 18kw Swing Tank



Job Name	Location		
Purchaser	Engineer		
Submitted to	Reference <input type="checkbox"/>	Approval <input type="checkbox"/>	Construction <input type="checkbox"/>
Unit Designation	Schedule #		

Specifications	GS5-45HPC & -D
Performance	
Capacity per Heat Pump	4.5kw or 15,400 Btu/h
Recovery per HP @ 90°F Rise	20.6 Gallons per Hour
Swing Tank	
ECO-200SW18	
Tank Volume Actual/Nominal	200 Gallons
Pressure Relief Valve (Psig & °F)	150 Psig
Temperature Sensor	Immersion Thermostat
Installed Tank Weight (lbs)	550lbs
Shipping Tank Weight (lbs)	742lbs
Anodes	3 x Magnesium
Tank Connection Sizes	
Recirc/HP Manifold Inlet	1 1/2" NPT
Hot Water Outlet	1 1/2" NPT
Electric Elements	
Number of Elements	1
Element Output	18kw
Number of Element Contactors	2
Amperage Draw -Various Power Supplies	
208V-1Ph	87.0A
240V-1Ph	75.0A
208V-3Ph	50.0A
240V-3Ph	44.0A
Approvals	
Tank	ASME
	ETL & ETLc
Warranty	
Tank	5 Years

Construction

The tank shall be manufactured from carbon steel with an Ultonium glass lining is applied to the inside surface of the steel tank and fired to 1600°F. The Tank shall be constructed in accordance with the ASME code

Insulation

High-density closed cell foam insulation shall be used to meet the ASHRAE 90.1b current standard for minimizing heat loss. This requirement, allowing a maximum 4 watts per square foot of tank surface energy loss

Water Connections

Connections to the Recirculation loop and Hot Water from the GS5 Heat Pump Manifold shall be 1 1/2"

Electric Element

Low Watt Density Incoloy Element shall be used to ensure that the element resists the effects of high operating temperatures, hard water acids, corrosion and thermal shock in addition to water voids

Controls

Magnetic Contactors with Immersion Thermostats. 120 volt control circuit with built in transformer. Elements are thermostatically controlled in 54kw (Max) increments Internal fusing shall have the electric element and circuit fused in 48A increments to ensure electrical protection Cartridge type fuses shall be rated at 200,000 Ampere interrupting capacity Terminal Block Connections shall be provided to ensure field wiring Building Management Interface contacts shall be provided to ensure remote control of the Swing Tank

Pressure and Temperature Relief

Tank shall be supplied with a field installed, ASME approved Pressure relief valve Valve Setting shall be at 150 Psig Relief Valve shall be piped to a suitable location in case of discharge



SUBMITTAL : ECO-200SW18

200 Gallon & 18kw Swing Tank



Job Name	Location		
Purchaser	Engineer		
Submitted to	Reference <input type="checkbox"/>	Approval <input type="checkbox"/>	Construction <input type="checkbox"/>
Unit Designation	Schedule #		

Swing Tank Dimensions

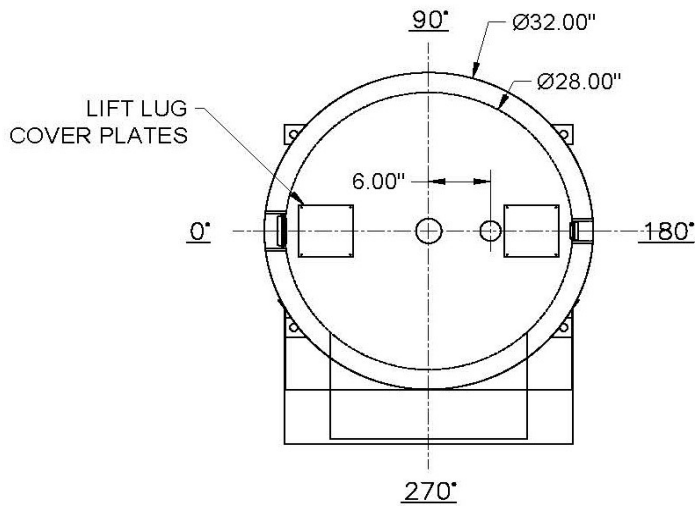

CUSTOMER:

CONSTRUCTION:

MATERIAL: CARBON STEEL
 INTERIOR LINING: ULTONIUM
 EXTERIOR: INSULATED W/ STEEL JACKET
 SACRIFICIAL ANODES: MAGNESIUM
 M.A.W.P.: 150 PSI
 MAX. OPERATING TEMP.: 180°F

ELECTRICAL COMPONENTS:

18KW / 240V / 1PH

OPTIONAL ADDERS:

A - BMS CONTACTS

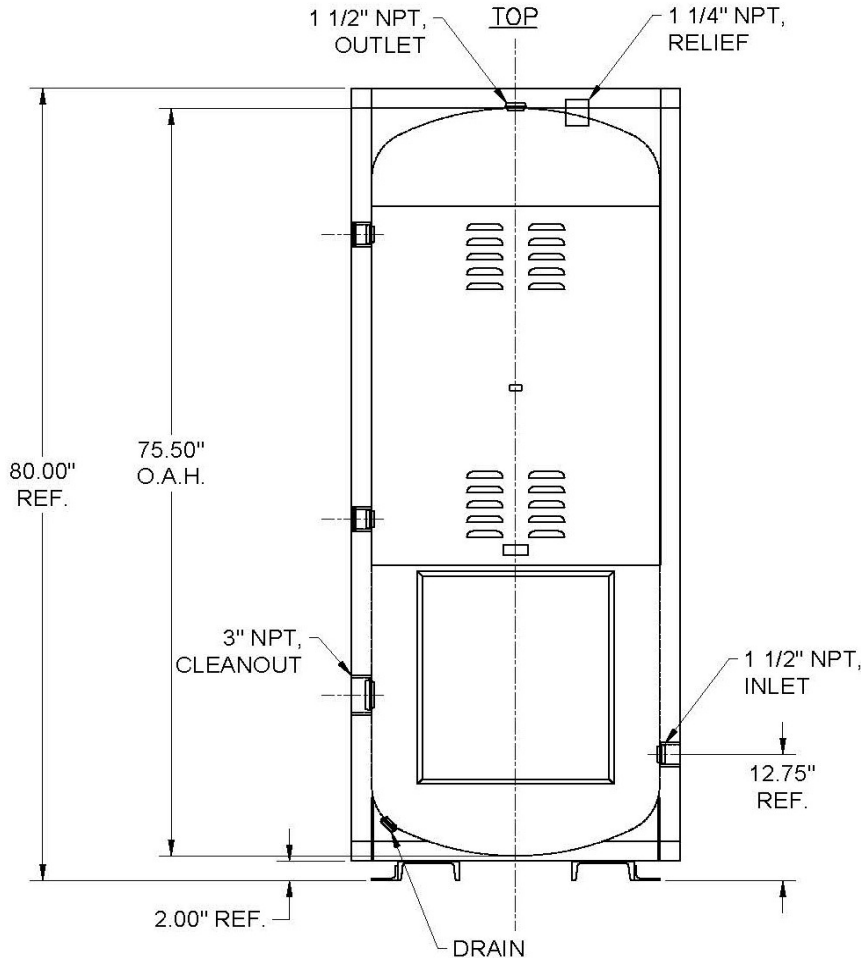

Eco2 Systems LLC

PO Box 1358, Walled Lake MI 48390, Tel : 1-844 SAND CO2 (1-844 726 3262)

www.eco2waterheater.com

Due to Eco2 Systems LLC's policy of on-going product development specifications are subject to change without notice

SUB-ECO2-200SW18-062024

© Eco2 Systems LLC 2024