



# SUBMITTAL : GS4-45HPC-D & SAN-119GLBK 119 Gallon Tank



Job Name	Location		
Purchaser	Engineer		
Submitted to	Reference <input type="checkbox"/>	Approval <input type="checkbox"/>	Construction <input type="checkbox"/>
Unit Designation	Schedule #		

Specifications	GS4-45HPC-D
<b>Performance</b>	
Uniform Energy Factor	3.40
Uniform First Hour Rating	135 Gallons
Nom Heating Capacity (Btu/h)	15,400 Btu/h
Nom Heating Capacity (kw)	4.5kw
Heating COP @ 80/47/17°F	5.5 / 4.2 / 2.8
Water Temperature Setting (°F)	145 or 150 DegF
Refrigerant Type	R744 (CO <sub>2</sub> )
Refrigerant Charge (Oz)	25.4oz (720g)
Power Voltage	208/230v-1Ph-60Hz
Breaker Size	15A
MCA (Amps)	7.2A
Compressor MRC (Amps)	5.0A
Fan Motor MOC/Watts	0.3A / 30W
Pump MOC/Watts	0.6A / 60W
Drain Pan Heater MOC/Watts	0.6A / 132W
Noise Level (DbA)	37
Weight (lbs)	110lbs
<b>Storage Tank</b>	
<b>SAN-119GLBK</b>	
Nominal Volume	119 Gallons
Pressure Relief Valve (Psig & °F)	150 & 210°F
Temperature Sensor	Thermistor
Tank Weight (lbs)	345lbs
Standby Loss in 67°F Ambient	107 Btu/h
<b>Tank Connection Sizes</b>	
Cold Water Inlet	1 1/2" NPT
Hot Water Outlet	1 1/2" NPT
Cold Water to Heat Pump	3/4" NPT
Hot Water Return from HP	3/4" NPT
<b>Pipe Size - Tank to Heat Pump</b>	
Cold Water pipe - Tank to HP	1/2"
Hot Water pipe - HP to Tank	1/2"
Max Pipe Length inc	66ft
Max Vertical Separation of	23ft
<b>Certifications</b>	
Safety	ETL & ETLc
Performance	Energy Star
<b>Warranty - System</b>	
Heat Pump	3 Years Labor
Tank	10 Years Parts
	10 Years

### Construction

The Outdoor unit shall be galvanized steel with a baked on powder coated finish on all panels except for unit base

### Heat Exchangers

Evaporator coil shall be mechanically bonded Aluminum fin to copper tube. Fins shall be coated to resist corrosion

The Refrigerant to Water HX (Gas Cooler) shall be a Double Wall type pressure tested to 6000 psi

### Refrigerant System

Compressor shall be a hermetically sealed DC Inverter drive Rotary vane type  
Refrigerant shall be R744 (CO<sub>2</sub>).

Refrigerant flow shall be controlled by Electronic Expansion Valve

### Fan & Motor

The outdoor unit fan shall be a propeller type, driven by a BLDC Motor

### Water Pump

The pump shall be a BLDC Impellor type, with a maximum distance of 66ft including a vertical separation of 23ft from the Storage Tank

### Controls

The unit shall be operated using a temperature sensor mounted in the Storage tank

Control wiring shall require 16AWG shielded wire  
Ambient operating range shall be -25°F to 104°F

### Storage Tank

Storage tank shall be constructed from mild steel with a baked on Colbalt enriched porcelain lining  
Storage Tank connections shall be NPT. Storage Tank shall be supplied with Mixing Valve & PTR Valve

### Interconnect Piping

Interconnect Piping shall be 1/2" copper or where permitted 1/2" PEX tubing

Both Cold and Hot piping should be insulated with min 3/4" closed cell foam and where required Heat Trace tape shall be used to prevent pipes from freezing



# SUBMITTAL : GS4-45HPC-D & SAN-119GLBK 119 Gallon Tank



Job Name	Location			
Purchaser	Engineer			
Submitted to	Reference <input type="checkbox"/>	Approval <input type="checkbox"/>	Construction <input type="checkbox"/>	
Unit Designation	Schedule #			

## GS4-45HPC-D Dimensions

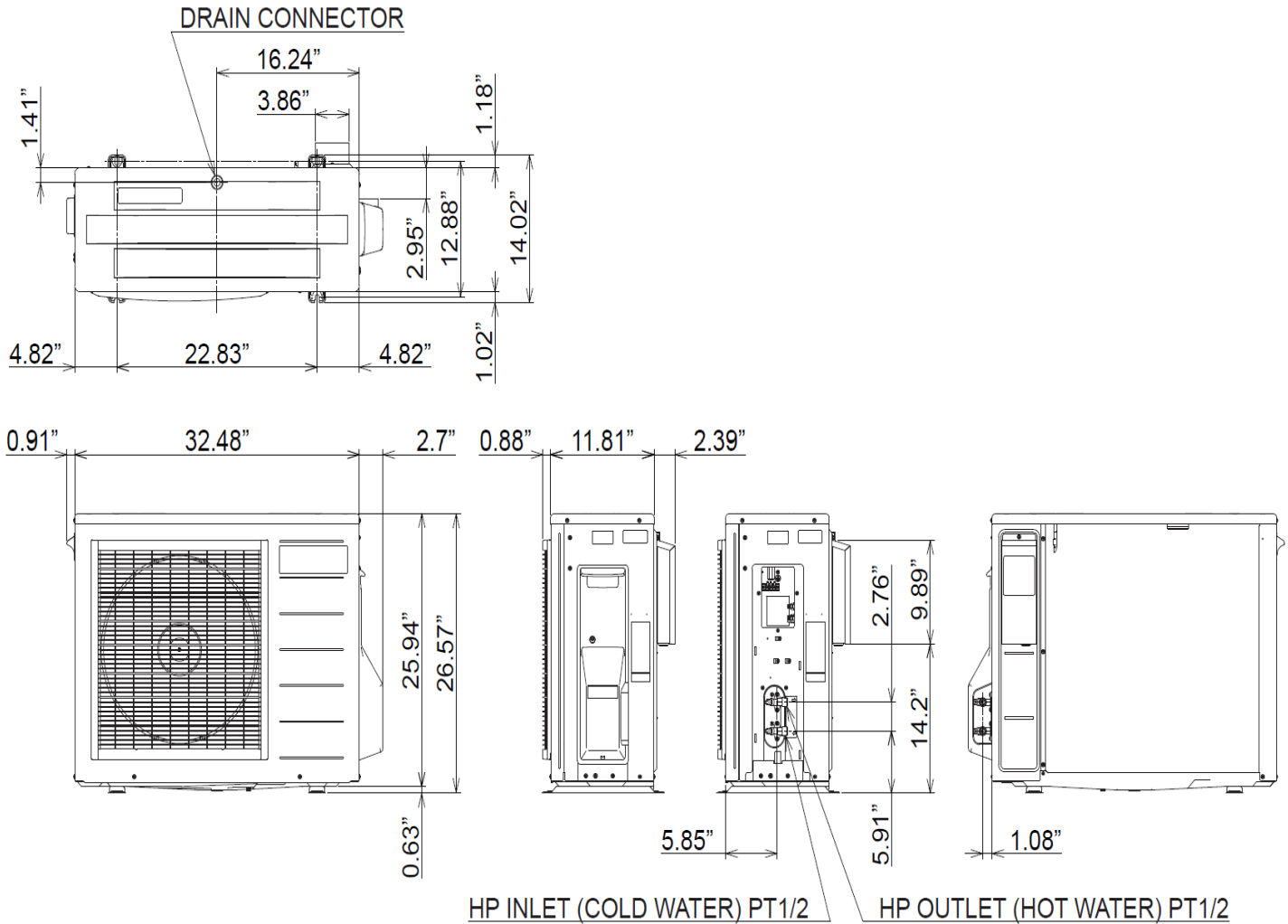

Unit:inch



# SUBMITTAL : GS4-45HPC-D & SAN-119GLBK 119 Gallon Tank



Job Name	Location		
Purchaser	Engineer		
Submitted to	Reference <input type="checkbox"/>	Approval <input type="checkbox"/>	Construction <input type="checkbox"/>
Unit Designation	Schedule #		

## SAN-119GLBK Glass Lined Storage Tank Dimensions

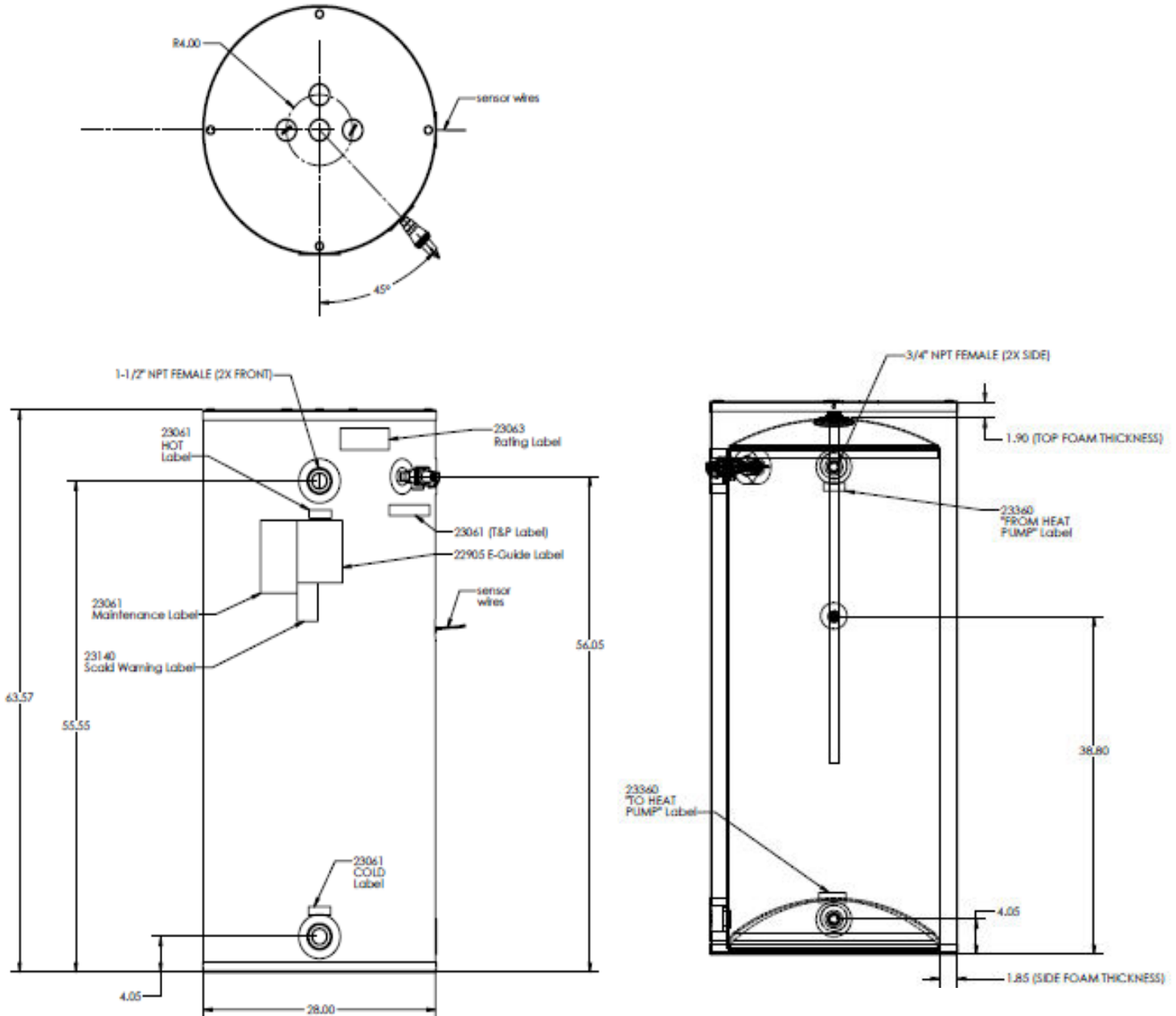

Eco2 Systems LLC

PO Box 1358, Walled Lake MI 48390, Tel : 1-844 SAND CO2 (1-844 726 3262)

[www.eco2waterheater.com](http://www.eco2waterheater.com)

Due to Eco2 Systems LLC's policy of on-going product development specifications are subject to change without notice

SUB-ECO2-GS4-D+119-042023

© 2023 Eco2 Systems LLC