



SUBMITTAL : GS4-45HPC-D & SAN-43SSAQA 43 Gallon Tank



Job Name	Location
Purchaser	Engineer
Submitted to	Reference <input type="checkbox"/> Approval <input type="checkbox"/> Construction <input type="checkbox"/>
Unit Designation	Schedule #

Specifications	GS4-45HPC-D
Performance	
Uniform Energy Factor	3.10
Uniform First Hour Rating	69 Gallons
Nom Heating Capacity (Btu/h)	15,400 Btu/h
Nom Heating Capacity (kw)	4.5kw
Heating COP @ 80/47/17°F	5.5 / 4.2 / 2.8
Water Temperature Setting (°F)	145 or 149 DegF
Refrigerant Type	R744 (CO ₂)
Refrigerant Charge (Oz)	25.4oz (720g)
Power Voltage	208/230v-1Ph-60Hz
Breaker Size	15A
MCA (Amps)	7.2A
Compressor MRC (Amps)	5.0A
Fan Motor MOC/Watts	0.3A / 30W
Pump MOC/Watts	0.6A / 60W
Drain Pan Heater MOC/Watts	0.6A / 132W
Noise Level (DbA)	37
Weight (lbs)	110lbs
Storage Tank	
SAN-43SSAQA	
Nominal Volume	43 Gallons
Pressure Relief Valve (Psig & °F)	125/150 & 210°F
Temperature Sensor	Thermistor
Tank Weight (lbs)	88lbs
Standby Loss in 67°F Ambient	91 Btu/h
Tank Connection Sizes	
Cold Water Inlet	3/4" NPT
Hot Water Outlet	3/4" NPT
Cold Water to Heat Pump	3/4" NPT
Hot Water Return from HP	3/4" NPT
Pipe Size - Tank to Heat Pump	
Cold Water pipe - Tank to HP	1/2"
Hot Water pipe - HP to Tank	1/2"
Max Pipe Length inc	66ft
Max Vertical Separation of	23ft
Certifications	
Safety	ETL & ETLc
Performance	Energy Star
Warranty - System	
Heat Pump	3 Years Labor
Tank	10 Years Parts
	15Yrs Limited Lifetime

Construction

The Outdoor unit shall be galvanized steel with a baked on powder coated finish on all panels except for unit base

Heat Exchangers

Evaporator coil shall be mechanically bonded Aluminum fin to copper tube. Fins shall be coated to resist corrosion

The Refrigerant to Water HX (Gas Cooler) shall be a Double Wall type pressure tested to 6000 psi

Refrigerant System

Compressor shall be a hermetically sealed DC Inverter drive Rotary vane type
Refrigerant shall be R744 (CO₂).

Refrigerant flow shall be controlled by Electronic Expansion Valve

Fan & Motor

The outdoor unit fan shall be a propeller type, driven by a BLDC Motor

Water Pump

The pump shall be a BLDC Impellor type, with a maximum distance of 66ft including a vertical separation of 23ft from the Storage Tank

Controls

The unit shall be operated using a temperature sensor mounted in the Storage tank

Control wiring shall require 16AWG shielded wire
Ambient operating range shall be -25°F to 104°F

Storage Tank

Storage tank shall be constructed from a blend of 316/444 Stainless Steel with R12 Insulation
Storage Tank connections shall be NPT

Connections shall be interchangeable as required

Interconnect Piping

Interconnect Piping shall be 1/2" copper or where permitted 1/2" PEX tubing

Both Cold and Hot piping should be insulated with min 3/4" closed cell foam and where required Heat Trace tape shall be used to prevent pipes from freezing



SUBMITTAL : GS4-45HPC-D & SAN-43SSAQA 43 Gallon Tank



Job Name	Location			
Purchaser	Engineer			
Submitted to	Reference <input type="checkbox"/>	Approval <input type="checkbox"/>	Construction <input type="checkbox"/>	
Unit Designation	Schedule #			

GS4-45HPC-D Dimensions

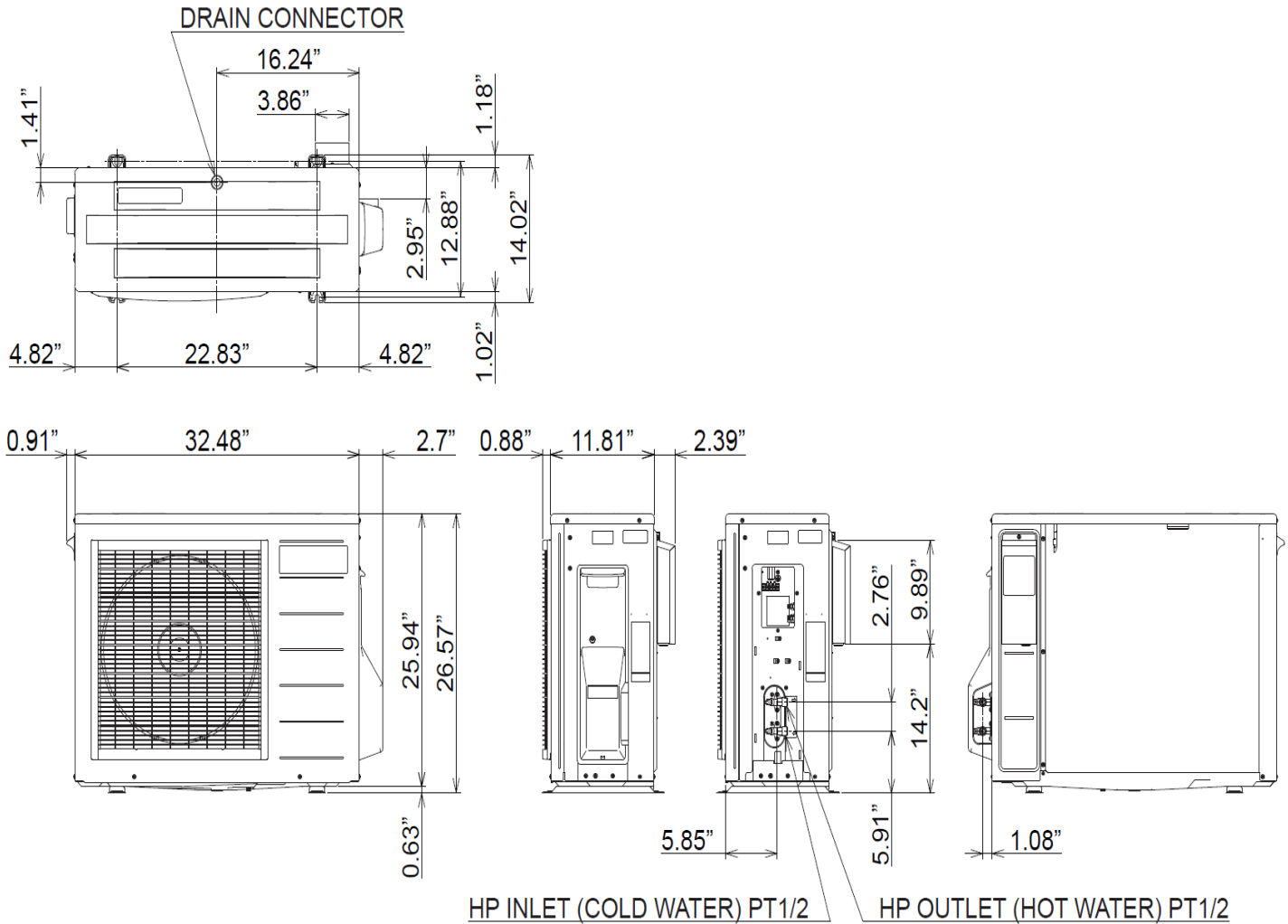

Unit:inch

Eco2 Systems LLC

PO Box 1358, Walled Lake MI 48390, Tel : 1-844 SAND CO2 (1-844 726 3262)

www.eco2waterheater.com



SUBMITTAL : GS4-45HPC & SAN-43SSAQA 43 Gallon Tank



Job Name	Location		
Purchaser	Engineer		
Submitted to	Reference <input type="checkbox"/>	Approval <input type="checkbox"/>	Construction <input type="checkbox"/>
Unit Designation	Schedule #		

SAN-43SSAQA Stainless Steel Storage Tank Dimensions

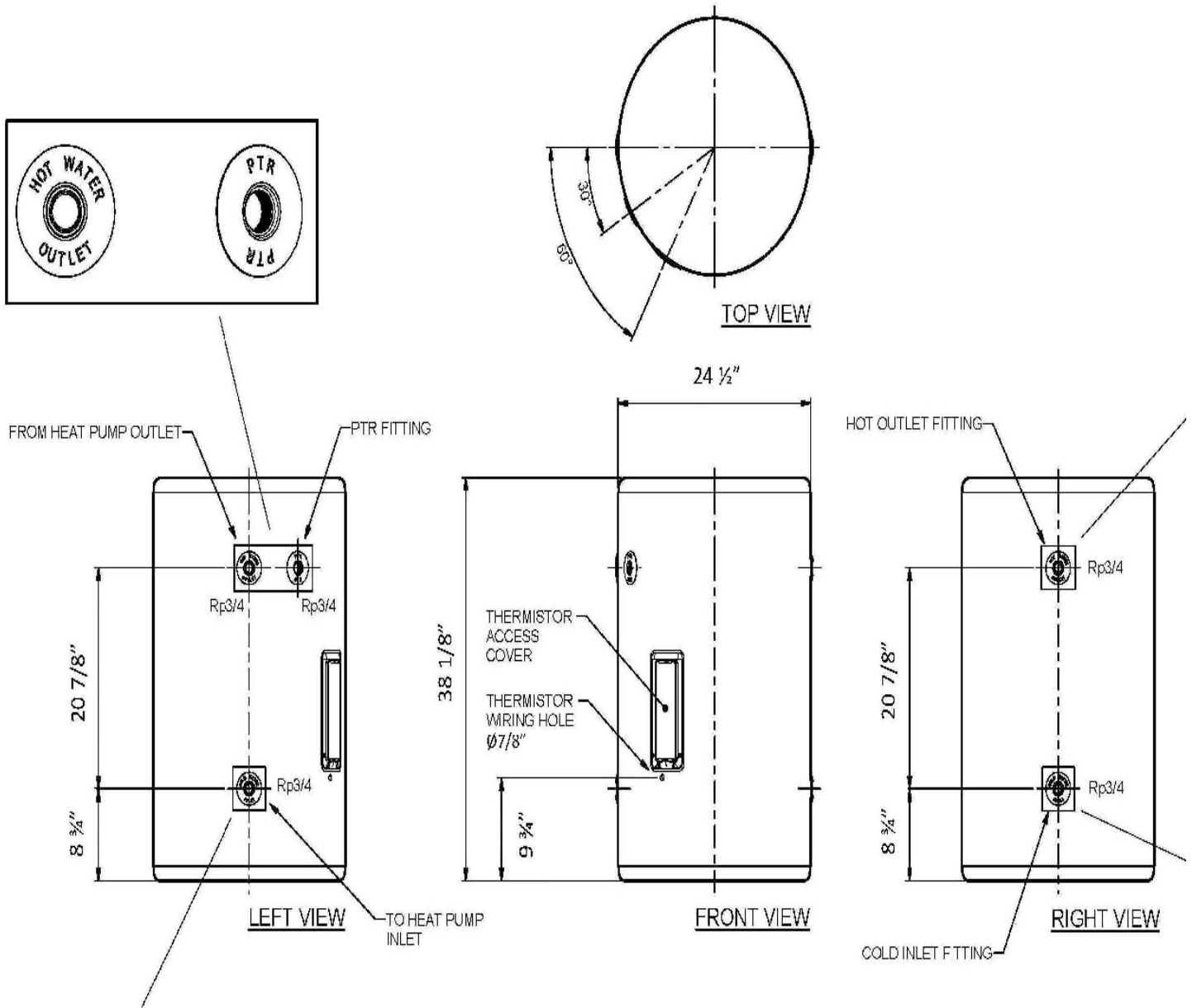

Eco2 Systems LLC

PO Box 1358, Walled Lake MI 48390, Tel : 1-844 SAND CO2 (1-844 726 3262)
www.eco2waterheater.com

Due to Eco2 Systems LLC's policy of on-going product development specifications are subject to change without notice
© 2023 Eco2 Systems LLC

SUB-ECO2-GS4-D+43-042023