



SUBMITTAL : SAN-83SSAQA

83 Gallon Storage Tank



Job Name :	Location
Purchaser	Engineer
Submitted to	Reference <input type="checkbox"/> Approval <input type="checkbox"/> Construction <input type="checkbox"/>
Unit Designation	Schedule #

Specifications	SAN-83SSAQA
Performance	
Uniform Energy Factor	3.75
Uniform First Hour Rating	115 Gallons
Design	
Nominal Water Storage Volume	83 Gallons
Pressure Relief Valve (Psig & °F)	150 Psig & 210°F
Temperature Sensor	Thermistor
Tank Weight (lbs)	115lbs
Standby Loss in 67°F Ambient	110 Btu/h
Tank Location & Clearances	
Tank Installation location	Indoor Exterior if ambient is always above 35°F
Tank Clearance required	2" around Tank
Tank Connection Sizes	
Cold Water Inlet	3/4" NPT
Hot Water Outlet	3/4" NPT
Cold Water to Heat Pump	3/4" NPT
Hot Water Return from Heat Pump	3/4" NPT
Press Relief Valve Discharge Line	3/4"
Pipe Size - Tank to Heat Pump	
Size	1/2" & 1/2"
Max Pipe Length inc	66ft
Max Vertical Separation of	23ft
Certifications	
Safety	ETL & ETLc
Performance	Energy Star
AHRI Certification reference #	TBA
Tank Warranty	
Tank	15 Years Limited Lifetime

Construction

Storage tank shall be constructed from a blend of 316/444 Stainless Steel pressure tested to 300 psi Tank outer shell shall be steel with a baked on powder coating for protection

Insulation

A minimum of 1 7/8" R12 polystyrene insulation shall be used to insulate the tank to reduce heat loss Insulation shall not contribute to global warming

Connections

All connections shall be 3/4" NPT Female type Brass adaptors will be supplied with tank Cold Water Piping from Storage Tank to Heat Pump and return of Hot Water piping from Heat Pump to Tank shall be 1/2" Copper or PEX. Reducing nipples shall be field supplied and installed

Controls

The tank shall be supplied with a Temperature sensor installed in a sensor well to control the GS4-45HPC Heat Pump Additional Heat Pump units connected to a tank shall require an individual Temperature sensor Additional Tank Water sensors shall be field installed Control wiring between Tank and Heat Pump model GS4-45HPC shall require a 2 wire 16AWG shielded wire between the Tank and GS4-45HPC Heat Pump

Pressure and Temperature Relief

Tank shall be supplied with valve to be field installed ASME certified Pressure and Temperature Relief valve Settings shall be at 150 Psig for Pressure and 210°F for Temperature

Mixing Valve

A factory supplied, but field installed Mixing or Anti Scald valve shall be supplied with the Tank Valve connections shall be 3/4" Female NPT Valve shall be field set to ensure delivered water temperature shall be below 120°F to prevent scalding



SUBMITTAL : SAN-83SSAQA

83 Gallon Storage Tank



Job Name	Location
Purchaser	Engineer
Submitted to	Reference <input type="checkbox"/> Approval <input type="checkbox"/> Construction <input type="checkbox"/>
Unit Designation	Schedule #

SAN-83SSAQA Dimensions

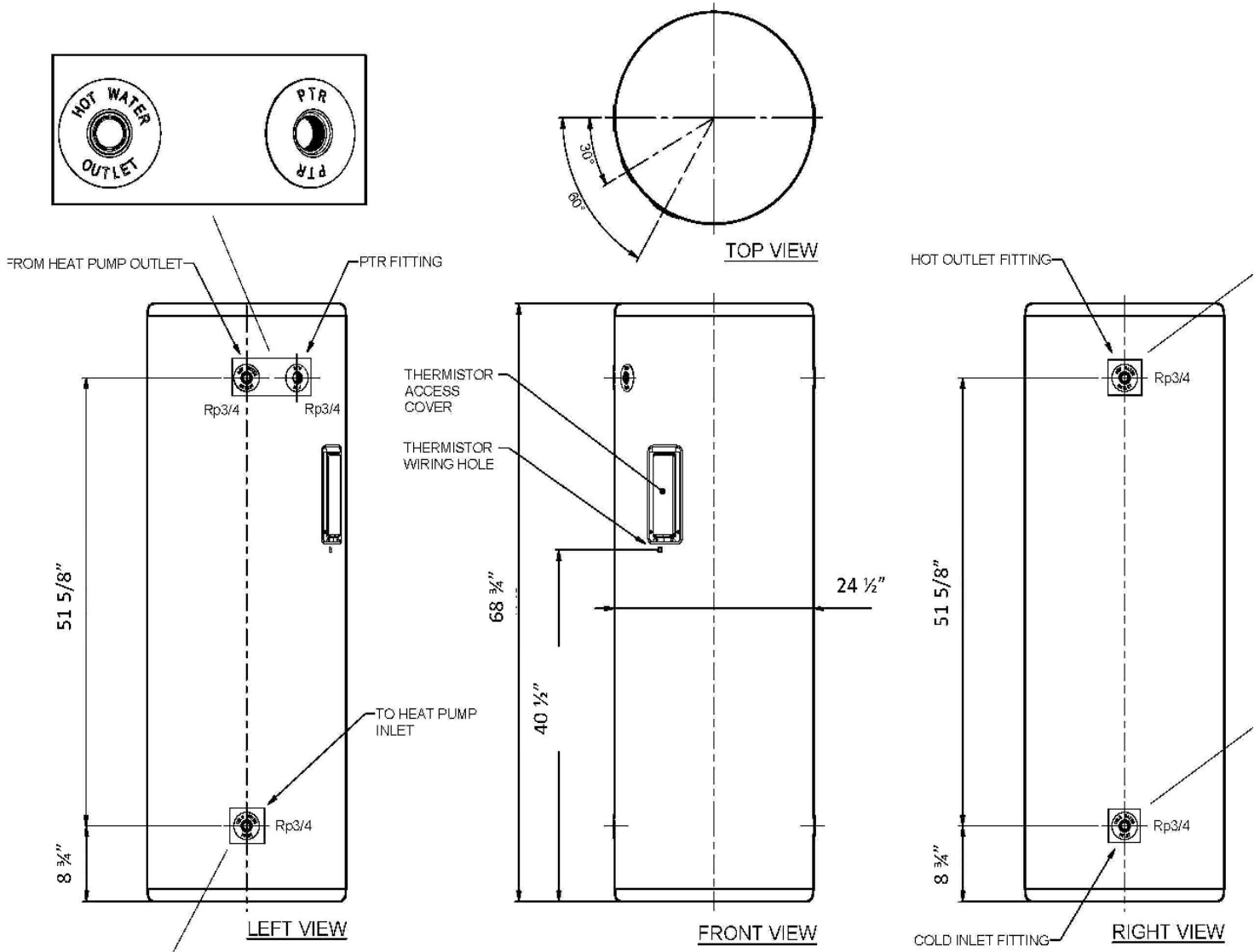

Eco2 Systems LLC

PO Box 1358, Walled Lake MI 48390, Tel : 1-844 SAND CO2 (1-844 726 3262)

www.eco2waterheater.com

Due to Eco2 Systems LLC's policy of on-going product development specifications are subject to change without notice

SUB-ECO2-SAN83-062023

© 2023 Eco2 Systems LLC