



SANCO₂ Technical Book

Advisory note:

Basic knowledge of hydronics, refrigeration, electricity and thermodynamics is required to fully understand this material.

Thank you for your attention, the ECO₂ Technical Team.

John Miles

Maho Ito

ECO₂ Systems LLC
P.O Box 1358, Walled Lake, MI 48390

Customer Service: 844 726 3263

Technical Support : 844 726 3263 x 403

Email: info@eco2systemsllc.com

Website: www.eco2waterheater.com



Table of Contents

3	About SANCO₂
5	Applications—Residential
6	Applications—Commercial
8	Applications—Combination Heating & DHW
9	Unit Operation
10	Hot Water Recovery
11	Efficiency, Capacity vs Ambient
12	Pre-Installation Check List
14	Installation Tips
15	Freeze Protection
17	Drain Down Valves
18	Hot water Recirculation
19	Inside the Heat Pump (Main Components, Electrical Components)
22	Heat Pump Control Modes
23	Error Codes
30	Trouble Shooting Guide
31	Temperature Thermistor Resistance Table
32	Maintenance
34	Warranty
35	Celsius to Fahrenheit Conversion Chart
36	Glossary
37	Notes





About SANCO₂

SANCO₂ is a customized CO₂ refrigerant Heat Pump Water Heater (HPWH) that is designed to meet North American market needs.

It is based on the Eco Cute units, which are a widely accepted and commonly used water heater in Japan and were first introduced to the market in 2001.

An Eco Cute is a HPWH that uses Carbon Dioxide (CO₂) as a refrigerant. “Cute” translates to hot water in Japanese which is pronounced “Kyuto”.

Since 2011 John and Maho have collaborated with local utility companies to conduct laboratory and field testing to ensure that the technology will transfer to the North American market without problems.

Why CO₂

Carbon dioxide (CO₂) is a unique refrigerant that does not contribute to global warming.

The Global Warming Potential (GWP) of carbon dioxide is 1, compared to the GWP of the typically used HWHP’s refrigerants such as R134a—GWP of 1,430 and R410a—GWP of 2,086.

CO₂ is used as a benchmark to measure Global Warming, so these numbers translate that 1 lb. of CO₂ released into the atmosphere will contribute 1 lb. Global Warming Potential. 1 lb. of R134a will contribute 1,430 lbs. of Global Warming Potential for 100 years.

ECO₂ utilizes 25.4 oz. of CO₂ refrigerant which is charged and stored inside of a closed loop system with an operating pressure range of 600 psi to 1,600 psi.

Carbon dioxide rarely achieves its liquid state. After being compressed and heated, the CO₂ refrigerant becomes as dense as liquid, while still remaining as a gas (trans-critical state), substantially increasing the transfer of heat between itself and the water, especially in low ambient temperatures.

In addition to the refrigerant attributes mentioned above, carbon dioxide extracts heat even at very low temperatures. The unit operates down below -25°F without a back-up heating element, and will deliver a maximum water temperature of 150°F.

Think of it this way—the outside air will transfer heat to the CO₂ through an evaporator. The CO₂ is then heated through compression. The heat from the CO₂ is transferred to the cold water through a double wall heat exchanger, and the hot water is pumped from the unit.

In the unlikely event of a refrigerant leak, the system can be recharged with CO₂ as would a normal HVAC system, however we recommend contacting ECO₂ Technical Support for information on this procedure.



What advantages are there?

Energy Efficiency

- SANCO₂ unit is 4 x more efficient than traditional electric water heaters. It uses much less energy to heat water faster
- SANCO₂ unit is more efficient in field testing than integrated HPWH's

High Performance

- Greater first hour rating than all HPWH's
- 43 Gallon tank—FHR 69 gallons
- 83 Gallon tank— FHR 115 gallons
- 119 Gallon tank—FHR 135 gallons
- Temperature produced between 145°F and 150°F, delivering hotter water than all other residential electric water heaters
- Faster recovery, approximately 18 to 20GPH delivered to the top of the tank

Extended Operating Range

- Hot water production down to -25°F and below
- No need for back up electric water heater in the storage tank

Flexible Installation

- Heat pump is installed outside, so no energy stealing from the space or cold airflow issues to overcome
- Heat pump has an extremely small footprint and low operation noise level making it suitable for installation almost anywhere
- Tank can be installed almost anywhere in the home or building. Power is not required or a large space required around the tank

High Quality with Low Maintenance

- Long life stainless steel tank (43 & 83 Gallon) with a 15 year prorated warranty
- No anode rods to replace or air filters to clean

Environmentally Friendly

- Minimal impact on global warming



Applications—Residential

Sizing

Sizing of the system to the needs of the occupants is **EXTREMELY IMPORTANT**.

43 Gallon Tank

First hour rating (FHR): 69 gallons. This tank size is suitable for families of 2 to 4 members

83 Gallon Tank

First hour rating (FHR): 115 gallons. This tank is suitable for families of 5+ members or families needing greater capacity.

119 Gallon Tank

First hour rating (FHR): 135 gallons. This tank is suitable for larger families of 8+ members or families needing greater capacity.

Heat Pump Outdoor Installation

The outdoor unit can be installed in various locations including: Directly outside a home, a garage, basement, mechanical room, or a suitable rooftop.

When mounting the unit, ensure no obstacles can prevent air flow across the unit (see installation manual for proper clearances).

If wall mounted installation is desired, the outdoor unit can be installed either high or low on a wall, but should be accessible in the event of maintenance. In areas with high snowfall, the unit must be installed above the anticipated snow line.

Heat Pump Indoor Installation

To avoid any ambient issues, locating the condenser inside of a building can be a viable alternative as long as the minimum 600 CFM (cubic feet per minute) of ventilation air requirements are met and can be maintained throughout use.

Tank Installation

The storage tank must be installed upright.

Installation clearances are 2" around the tank, no airflow is required so closet installation is not a problem.

No power is required for the tank, just water connections to the home and heat pump plus a control wire connection to the heat pump.

Maximum Distance

Maximum water piping from tank to heat pump is 66 ft. and the maximum vertical height or elevation of 23 ft.

Applications—Commercial

- Multi Family Living
- Assisted Living, Long Term Care
- Hospitality, Restaurants, Hotels
- Schools, Dormitories
- Health & Fitness Centers
- Office and Retail
- Co-op Laundry
- Agriculture

SANCO ₂ Commercial Hot Water Storage Tanks					
Model	ECO-200GLBK	ECO-285GLNST	ECO-360GLNST	ECO-455GLNST	ECO-505GLNST
Tank Capacity (Gallons)	200	285	360	455	505
Recovery per HP @ 90°F rise	20.5 GPH	20.5 GPH	20.5 GPH	20.5 GPH	20.5 GPH

In most multi-residential applications, multiple heat pumps units as well as tank units can be connected together to increase efficiency, hot water output, and recovery.

Sizing

When sizing for multi-family or other commercial applications, the following information is required to determine the number of heat pumps and tanks. Both the heat pump and tank unit are scalable depending on hot water usage.

The following information is required for water heater sizing:

- Number of Apartments & Floors in the building
- Daily hot water usage
- Peak hot water usage and time
- Number of bedrooms/bathrooms/kitchens/laundry per floors or apartment
- Expected number of residents per building
- Expected hot water draw pattern
- Specific hot water requirement for different applications

System Controller

Basic and BMS Staging controllers can be utilized to control up to 30 Heat Pump units in a maximum of 5 heating stages.

Multiple tanks can be used to provide hot water and the controller will be monitoring tank water temperature to send signal to the Heat Pump units to start.

Unit operation and error codes information is programmed back to the controller.

- Configured with SANCO₂ operating parameters and safety timers
- Monitors temperatures of Tank, Heat Pump Inlet, and Outdoor Air
- Unit alarm inputs with General alarm output relay
- Automatic freeze protection cycles heat pumps in extreme conditions
- Alternates unit starts to maintain balanced run times
- Commercial-grade hardware and components
- BMS models connect via Bacnet MS/TP or Ethernet/IP

Applications—Commercial

Installation

Like residential application, heat pumps can be installed indoor and/or outdoor depending on a building design, location, and climate.

Maximum water piping from tank to heat pump is 66 ft. and the maximum vertical elevation or height is 23 ft.

Heat Pump Outdoor Installation

The outdoor unit can be installed in various locations including: Directly outside a building, a garage, mechanical room, or a suitable rooftop.

When mounting the unit, ensure no obstacles that can prevent air flow obstruct the unit.

If wall mounted installation is desired, the outdoor unit can be installed either high or low on a wall, but should be accessible in the event of maintenance. In areas with high snowfall, the unit must be installed above the anticipated snow line.

Heat Pump Indoor Installation

The avoid any ambient issues, locating the condenser inside of a building can be a viable alternative as long as the minimum 600 CFM (cubic feet per minute) of ventilation air requirements are met and can be maintained throughout use.

Important

It is very important to install multiple heat pumps and tanks using the SANCO₂ Application Guide along with consultation with ECO₂ Technical and Design Support.



Installed system shown with 6 x Heat Pumps, 4 x SAN-119 gallon tanks and the SANCO₂ Controller for the system



Applications – Combination Heating and DHW

It is permitted to use the SANCO₂ system to provide some limited capacity heating (radiant, fan coil, etc.) in certain areas of North America, when combined with a minimum of 25 gallons per day usage of DHW.

It is NOT permitted to use the SANCO₂ system to provide heating as its only function.

Sizing

Maximum heating capacity must be less than 8,000 BTU/h.

Minimum design ambient temperature must be above 27°F.

Tank capacities of the 83 Gallon or 119 Gallon tank are required for performance.

DHW usage – minimum usage of 25 gallons per day.

Installation

Like residential applications, the heat pumps and tanks can be installed indoor and/or outdoor depending on a building design, location, and climate.

Maximum water piping from tank to heat pump is 66 ft. and the maximum vertical rise is 23 ft.

Installation location specifics must be as per the residential application.

Important

Per your local code, potable and non-potable water may need to be separated. Check with your local code authority to determine if separation, and/or use of a double wall heat exchanger is required.

In applications requiring separation between potable and non-potable water, SANCO₂ mandates the use of a Taco X-block system.

It is extremely important to install the combination system using the plumbing schematic provided by SANCO₂. Particular importance must be given to the location of the heating system return water pipe from the X-block to the tank, return water temperatures should return to the bottom of the tank.

Detailed planning and a meticulous installation is required, especially with multiple units piped together so that the entire installed system will function as it is intended.

Unit Operation

As hot water is drawn from the top of the tank for showers etc., cold water enters the bottom of the tank from the City or Well cold water supply feed.

The incoming cold water and stored hot water do not fully mix inside the tank (unlike other water heaters), this helps maintain a higher average tank temperature through stratification.

As more hot water is drawn from the tank, the volume of cold water increases, however the tank still remains stratified. When the tank temperature sensor measures the water temperature below 113°F, the heat pump control will start the unit.

The variable speed pump circulates the cold water into the heat pump, and using the heat from the ambient air the water is heated to 150°F and then returned to the top of the tank.

Heating continues until the water entering the heat pump heat exchanger is 126.5°F, at which point the heat pump will cycle off and the tank is now completely full of hot water.

The SANCO₂ unit will produce hot water at temperatures between 145°F and 150°F.

Therefore, it is mandatory to install the supplied 3/4" Mixing/Anti Scald valve.

Heat Pump Water Heater System

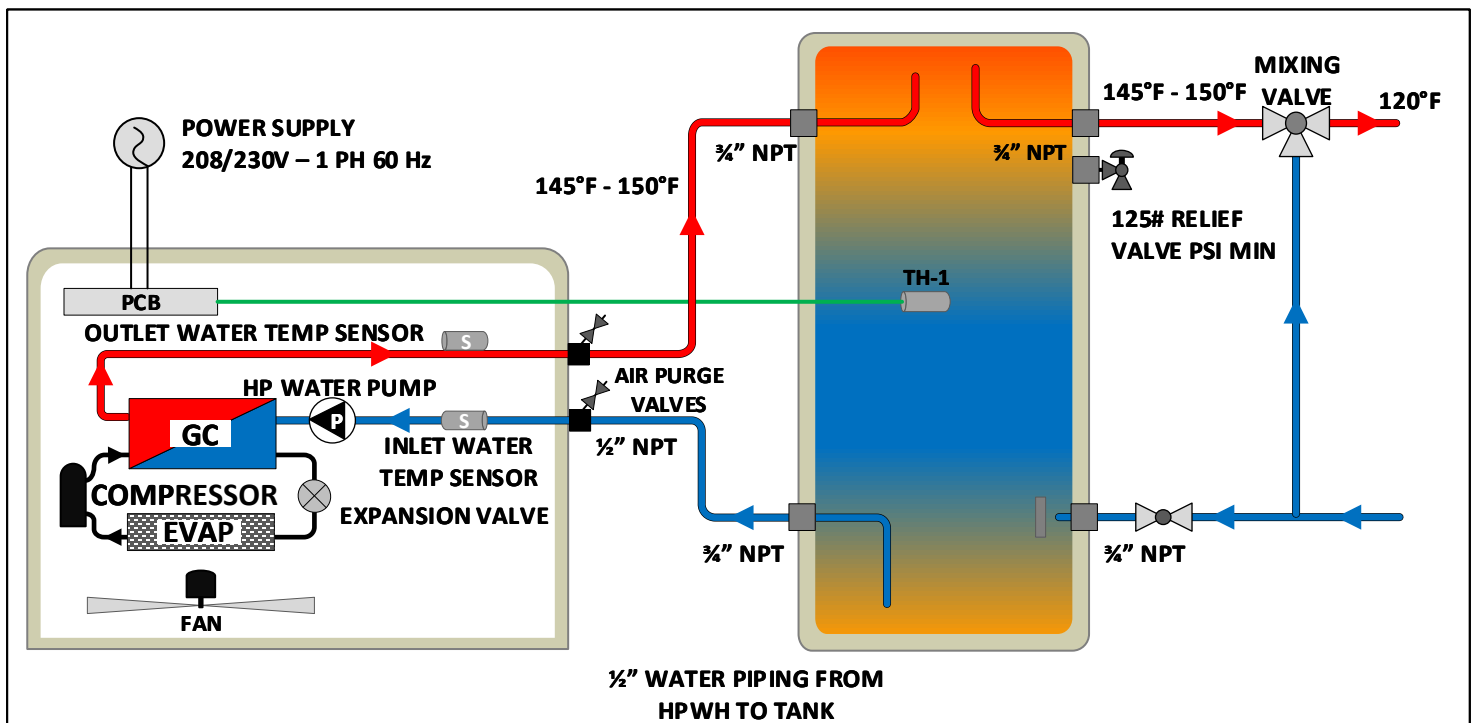



Hot Water Recovery

The SANCO₂ system capacity is rated at a minimum of 4.5Kw (15,400 Btu/h) at all ambient temperatures above 5°F.

Below 5°F, total capacity is reduced, the amount of reduction will depend on the outdoor temperature.

Above 5°F, the Hot water recovery for a SANCO₂ system is equivalent to any 4.5Kw electric water heater, however depending on incoming water temperature this recovery rate can alter.

Gallons per Minute (US GPM)						
	Incoming Water Temperature °F / °C					
Heat Pump Set Point	40 / 4.4	45 / 7.2	50 / 10	55 / 12.8	60 / 15.6	65 / 18.3
145°F / 62.8°C	0.29	0.31	0.33	0.34	0.36	0.39
150°F / 65.6°C	0.28	0.29	0.31	0.33	0.34	0.36
Gallons per Hour (US GPH)						
	Incoming Water Temperature °F / °C					
Heat Pump Set Point °F	40 / 4.4	45 / 7.2	50 / 10	55 / 12.8	60 / 15.6	65 / 18.3
145°F / 62.8°C	17.6	18.5	19.5	20.6	21.8	23.2
150°F / 65.6°C	16.8	17.6	18.5	19.5	20.6	21.8

This table shows the recovery flow for a single heat pump unit with the varied cold water flow temperature from the Tank to the Heat Pump.

The flow rate given is the flow from the heat pump to the tank, not flow into the home/appliance. The recovery rate from the Heat Pump is the same for any capacity tank.

In multiple heat pump systems, simply multiply the GPH by the number of heat pumps to calculate system recovery flow.

The SANCO₂ system will consistently produce 150°F hot water down to 65°F ambient temperature and then 145°F down to -25°F outdoor ambient.

These temperatures will increase the total delivered recovery of the tank with the hot water supply from the Heat Pump.

The hot water from the tank will then become mixed with cold water at the, Mixing/Anti Scald Valve which will then provide the delivered water temperature to the home, to prevent scalding and potential injury.

For example:

3 GPM hot water flow into the home;

The Anti Scald valve can be set for a temperature of 120°F delivered to the faucet

Using a cold incoming water temperature of 50°F to the Mixing/Anti Scald Valve this will require 2.1 GPM of tank hot water and 0.9 GPM of cold water to be mixed for the 3 GPM to be delivered.

Efficiency, Capacity vs Ambient

Unit efficiency is affected by delivered water temperature and outdoor ambient Unit capacity is ONLY affected by outdoor ambient.

Annual efficiency can be approximated using the system Coefficient of Performance at the various ambient temperatures.

Coefficient of Performance (COP) is calculated by dividing capacity by power input.

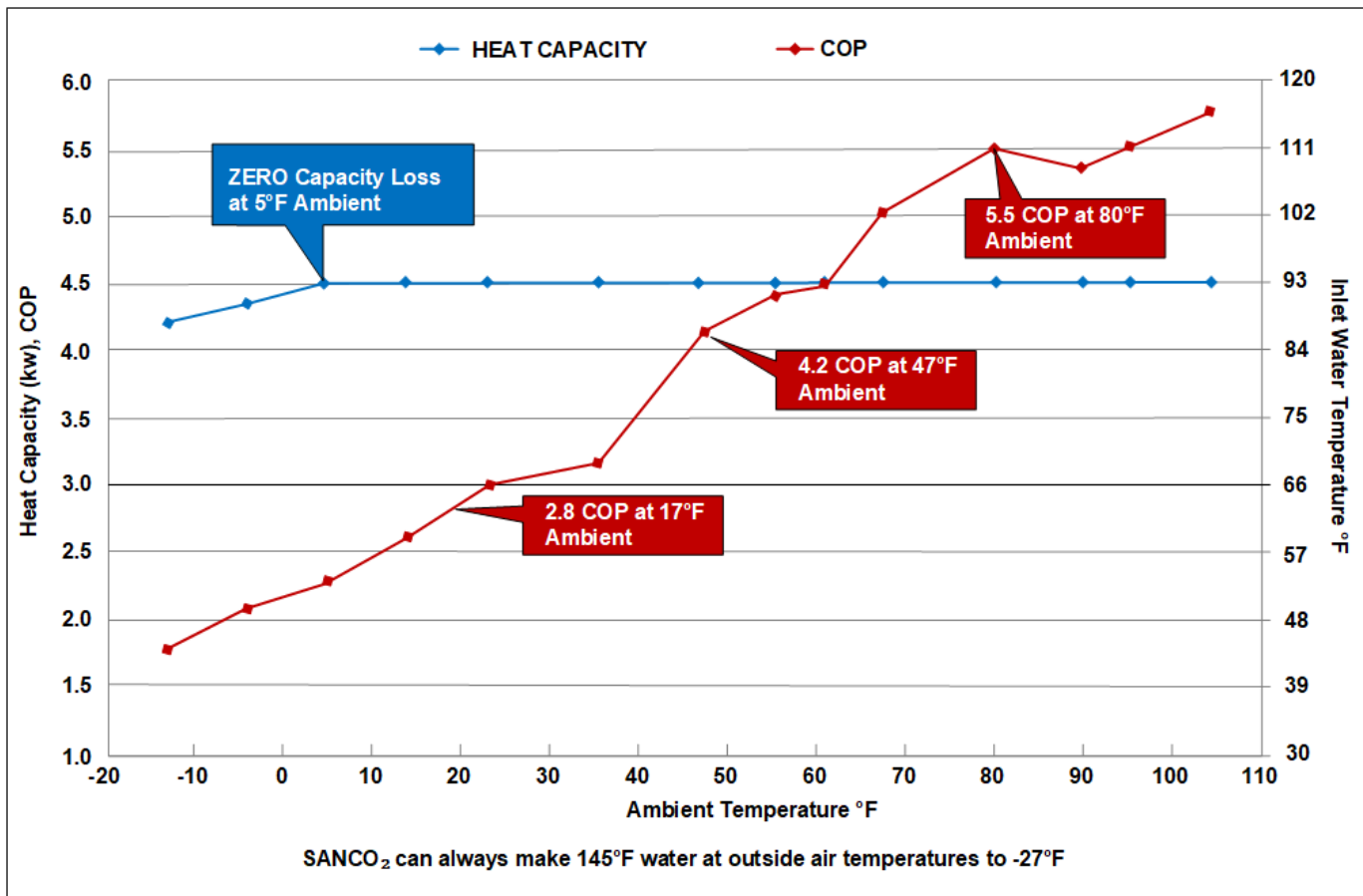

As can be seen, at 5°F ambient the system COP is over 2.0, which rises to over 4.0 at 47°F ambient, rising to 5.0 at 67°F ambient and 5.5 at 80°F ambient



Installation

Pre-Installation Check List

Unit application sizing and plumbing planning

Refer to this manual for information on the sizing and requirements/limitations for the specific application required. If in doubt, call technical support for advice.

Electrical Requirements

The outdoor unit should be fed with main power from the breaker and local disconnect (per NEC code). Wire sizing should be calculated based on Minimum Circuit Ampacity and wire length.

The unit is provided with a 16ft thermistor cable to connect to the terminal block, use a 16-2 or 18-2 AWG shielded wire to extend the thermistor cable from the heat pump unit to the tank.

Ensure the breaker size and voltage is correct for the system.

SANCO₂ units do not have start components for the compressor, and therefore they rely on the correct power and amperage supply to start:

Unit	Power Supply	Breaker Size
GS4-45HPC	208/230V—1Ph-60hz	15 Amps

Voltage tolerance is 187V to 253V.

Pipe Length and Sizes

Ensure that the maximum piping lengths are observed or the system will not operate correctly and will likely experience premature failure of its components.

Do not up-size or alter the piping length from those published as ECO₂ cannot guarantee operation with incorrectly installed piping.

For a GS4-45HPC unit the pipe length should not extend more than 66 ft. in length with 23 ft. in height or elevation, with a maximum of 6 bends in each pipe run between the tank and heat pump unit.

The piping size between the heat pump and tank unit MUST be ½" diameter and should be either copper or PEX piping.

Water supply piping to the tank, and from the tank to the building MUST be a minimum of 3/4" and should be either copper or PEX piping, depending on local code requirements.

ALL piping external to the building or in an unconditioned space MUST have a minimum 3/4" thick closed cell insulation with all joints taped, ensuring none of the system piping is exposed



Water Quality

Water with high concentrations of chloride that exceed 0.1 ounces per gallon (200mg/litre) can cause corrosion and subsequent failures, and thus the warranty will be no longer valid for the heat pump unit and tank unit.

No warranty coverage is given on the heat pump unit and tank unit where the PH is less than 6.0.

Supply water with a PH less than 6.0 may be treated to raise the PH and it is recommended that an analysis of the supply water be conducted before connecting the heat pump unit to the system.

Changing, or alternating, from one water supply to another can have a detrimental effect on the operation and/or life expectation of the water tank, PR valve, water heating circulation and the heat exchanger in the system and should be tested to ensure it meets the warranty requirements in the installation manual.

Tank Unit Positioning

If installing the tank unit indoors or in an enclosed space, leave at least 2" of clearance around the back and sides of the tank.

SANCO₂ tanks have all of the connections on the sides of the tank, not the top of the tank like the majority of the North American water heaters.

Ensure adequate clearance for the connections and piping to the tank and the piping for the supplied Mixing/Anti Scald Valve is maintained.

Outdoor Unit Positioning

Ensure that a minimum distance of 6" behind the unit and 12" in front of the unit is maintained, otherwise, the condenser airflow could be affected.

Ensure adequate access for service and setting panel operation is provided.

Access to the Heat Pump unit can be obtained by removing the top cover and front cover of the unit and all valve and electrical connections are on the RHS of the outdoor unit when looking at the condenser fan.

ECO₂ recommends a minimum of 18" separation when stacking the units vertically and 24" for RHS service access.

Error Codes

Errors occur typically because the system has either:

Too little flow of water from the tank to the heat pump, incorrect voltage to the system, and/or has not been purged of air in the water on start up.

Installation

Installation Tips

Condensate

As the unit is taking heat from the outside air, the coil on the unit will be colder than the ambient temperature. Depending on the outside air humidity level the unit will produce condensate. Volume of condensate will depend on the current humidity level.

It is very important that this condensate be drained away from the outdoor unit and the outdoor unit **MUST** be raised a minimum of 4" from the ground for installation.

In areas where winter design temperature is below 32°F, ECO₂ recommends NOT installing the drain hose connector and drain hose to the unit.

This is particularly important in areas exposed to freezing weather as the melted condensate from defrost could create a slip and fall hazard.

Defrosting of the outdoor coil occurs to remove frost buildup on the coil, the unit will calculate at what point to defrost based on operating conditions.

The unit is supplied with a ⁵/₈" drain hose connector for a hose to drain away the condensate (this items can be found in the base of the heat pump packaging).

Tank Connections

All tank connections are ³/₄", this is designed to allow flexibility in the tank installation due to site conditions.

For the piping from the tank to the heat pump, 2 x ³/₄" to ¹/₂" reducers are required.

Multiple heat pump systems

For systems with multiple heat pumps attached to a single tank, every heat pump requires its own individual thermistor.

The thermistor should be securely fitted in the thermistor well and secured with silicon or thermal paste. If using several thermistors, push the first thermistor as deep into the well as it will possibly go, then follow up by inserting additional thermistor).

Only one thermistor can be connected through the terminal block on the tank, with the other thermistors should then be wired directly to the other heat pump units' thermistor wires.

Existing Tanks

SANCO₂ tanks have been developed to maximize performance and efficiency. For correct unit operation, it is important that the heat pump receives cold water, therefore we do not permit existing water heaters or tanks to be used.

Freeze Protection

The basic design for a SANCO₂ system requires piping potable water to the heat pump. Heat Pump systems are designed to be able to lift water temperatures over 100°F quickly and efficiently.

This results in water being potentially exposed to freezing outdoor temperatures, so strategies are set up both in installation and the unit control system to minimize the potential of a freeze-up.

1. Minimal Water Piping Outdoors – Plan your job site and unit location to penetrate into the building adjacent to the heat pump
 Use ¾” minimum thick Closed Cell insulation on the external piping
 Tape joints and ensure that none of the system piping is exposed
2. Control Logic - Unit measures Inlet water temperature or outlet water temperature below 37°F (3°C), with an outside air temperature less than 37°F (3°C).
 When the outside temperature of piping becomes lower than the specified values and the heating setting mode is ON (including within the block out time) the anti freezing control is started.

However operation is not performed when the heating setting mode is OFF.

<u>Start trigger</u>	①	Ambient temp. $\leq 37^{\circ}\text{F}$ (3°C)	Freezing prevention operation started when ① and ② were achieved.
	②	Outlet temp. $\leq 37^{\circ}\text{F}$ (3°C) or Inlet temp. $\leq 37^{\circ}\text{F}$ (3°C)	
<u>End trigger</u>	①	Ambient temp. $\geq 43^{\circ}\text{F}$ (6°C)	Freezing prevention operation ends when ① or ② is achieved
	②	Outlet temp. $\geq 43^{\circ}\text{F}$ (6°C) [Detected for 150 seconds] and Inlet temp. $\geq 125^{\circ}\text{F}$ (52°C) [Detected for 150 seconds]	

Trace Heat - To protect the piping between the tank and heat pump, we require that trace heat be installed in applications where the winter design ambient is below 34 to 36°F.

Self-regulating trace heat at 6W per foot is recommended. ECO₂ recommends our official Heat trace cable accessory : Part # FG2-6L 6ft length of trace heat cable, with connection for 208/230V Power.

This length is designed to install on both the hot and cold water pipes attached to the unit and connected to the mains voltage wiring for the unit.

The ECO₂ trace heat cable selected will regulate based on the exact temperature down to the inch that the cable senses.

ECO₂ recommends that the trace heat cabling start at the top connection set, then wrap around the hot water supply piping (under the insulation) and cross over to the cold water inlet piping inside the building (minimizes the length of cable exposed to the air, then finish at the bottom connection set.

Follow the instructions provided in the trace heat kit for detailed information on the cable instruction.

Field testing has shown that when correctly installed, self-regulating trace heat will use less than 0.3% of the total energy consumed by the SANCO₂ unit.

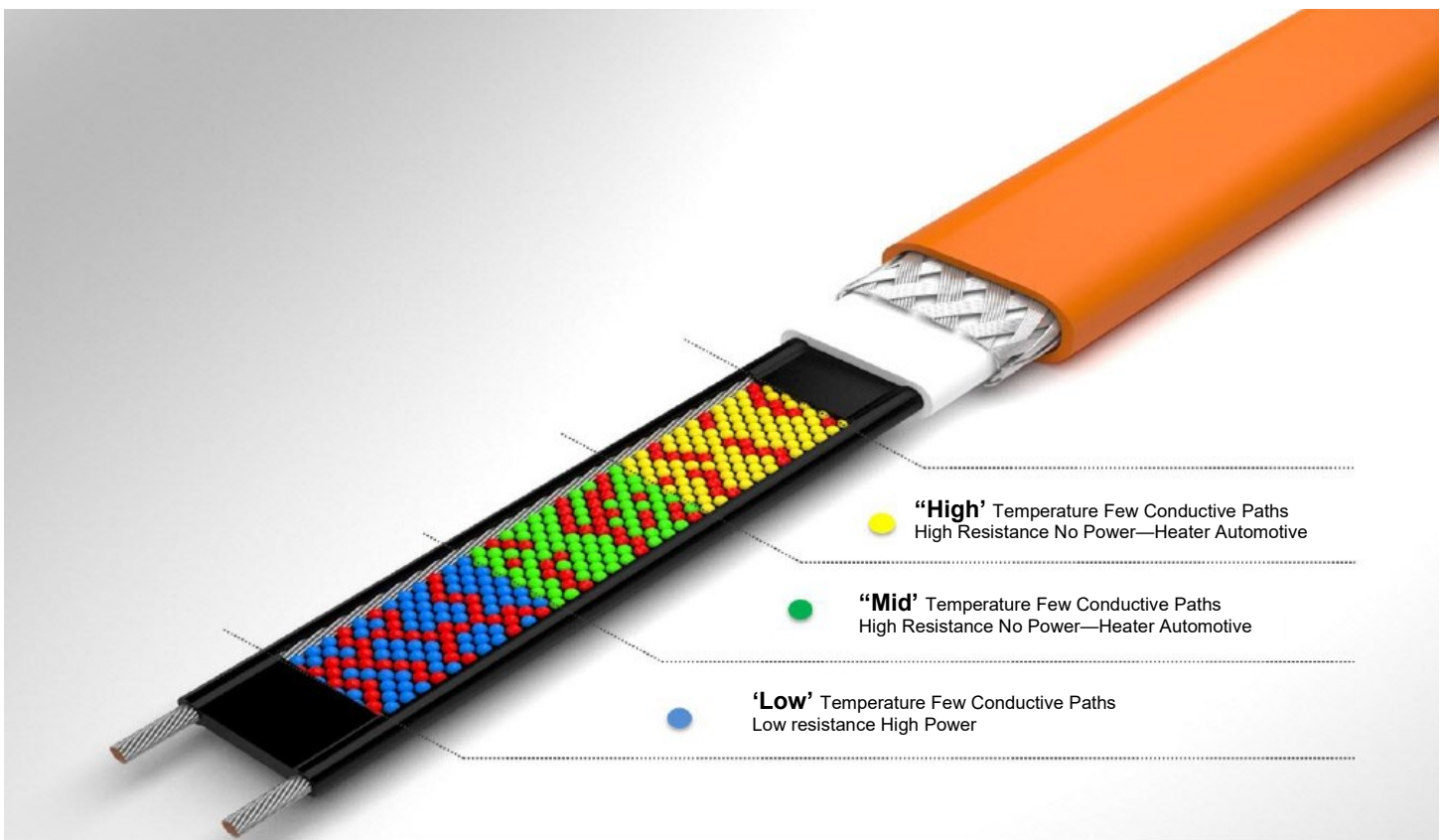



Drain Down Valves - To protect the piping between the tank and heat pump, we require that Drain Down Valves be installed in applications where the water design temperature is below 39°F.

Two 1/2" Drain Down Valves are installed on both the Cold Water piping from the Storage Tank to the Heat Pump and the Hot Water piping from the Heat Pump to the Storage Tank. No power or voltage is required for these valves.

The Drain Valves are designed to start opening at 39°F when the valves sense water temperature at the 39°F. Valve will be fully open at 35°F. As water temperature rises due to temperature or ambient the valves will close and standard operation will be continued.

ECO₂ recommends that both valves be installed on the water piping close to the Heat Pump location and the valve outlets of the low water temperature will be used to remove the water.

Follow the instructions provided in the FPVKT3540 Drain Down Valve kit for detailed information on the installation.

Hot Water Recirculation

These types of systems are often used to ensure hot water is available at the furthest fixture from the storage tank.

Multiple types of recirculation systems are available commercially. ECO₂ only permits the use of systems that use either a sensor or an aquastat to control the pump.

Timer systems are not permitted.

The recirculation system should only operate to clear the plug of cold water from the piping, typically this plug is less than 2 gallons in a residential application.

For commercial recirculation applications – please contact Technical Support.

Copper Pipe (Type M)		PEX Pipe	
Pipe Size	Gallons/foot	Pipe Size	Gallons/foot
1/2"	0.01319	1/2"	0.009609
3/4"	0.02685	3/4"	0.01894
1"	0.0454	1"	0.03128
1 1/4"	0.06804	1 1/4"	0.04668
1 1/2"	0.09505	1 1/2"	0.06516

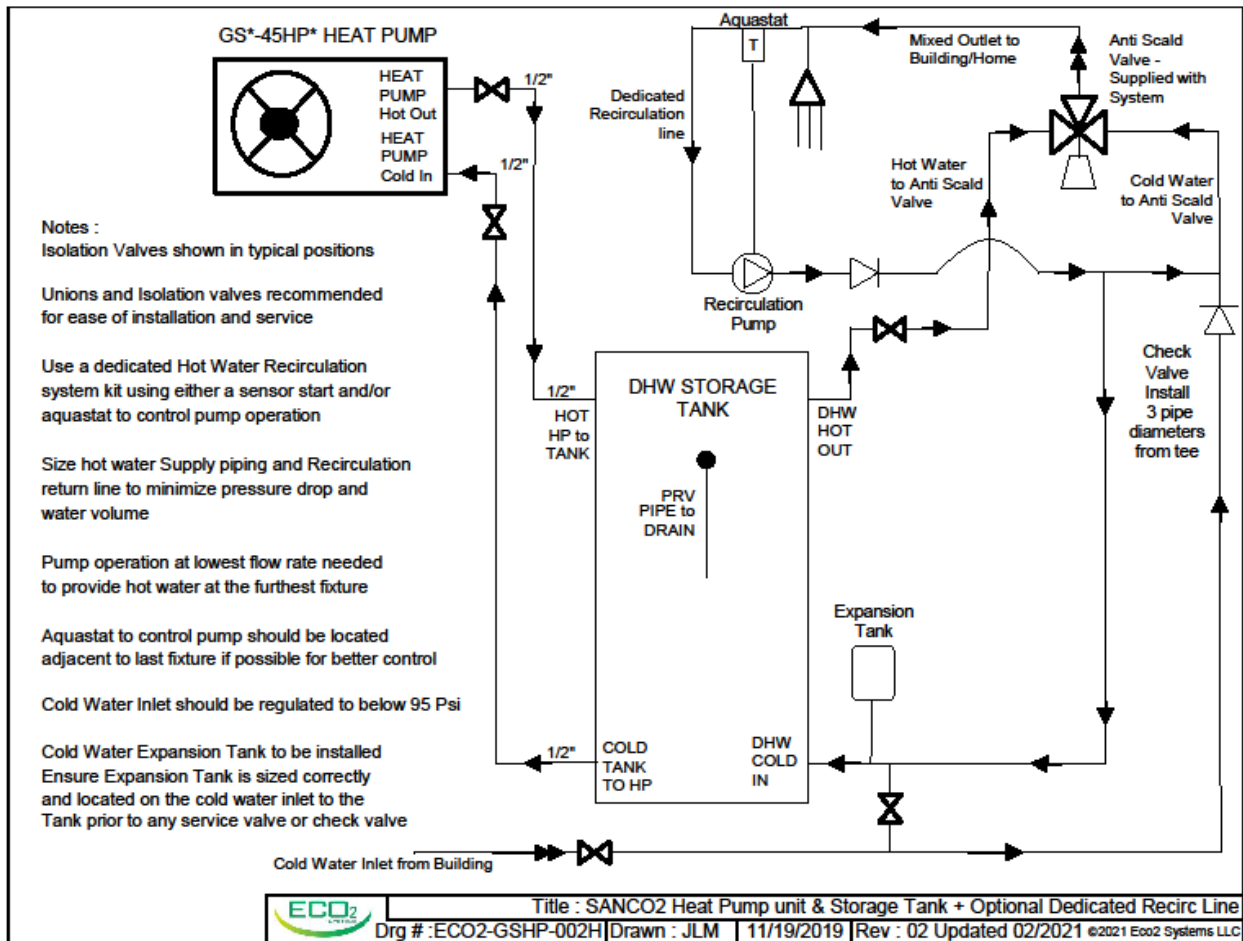

Inside the Heat Pump

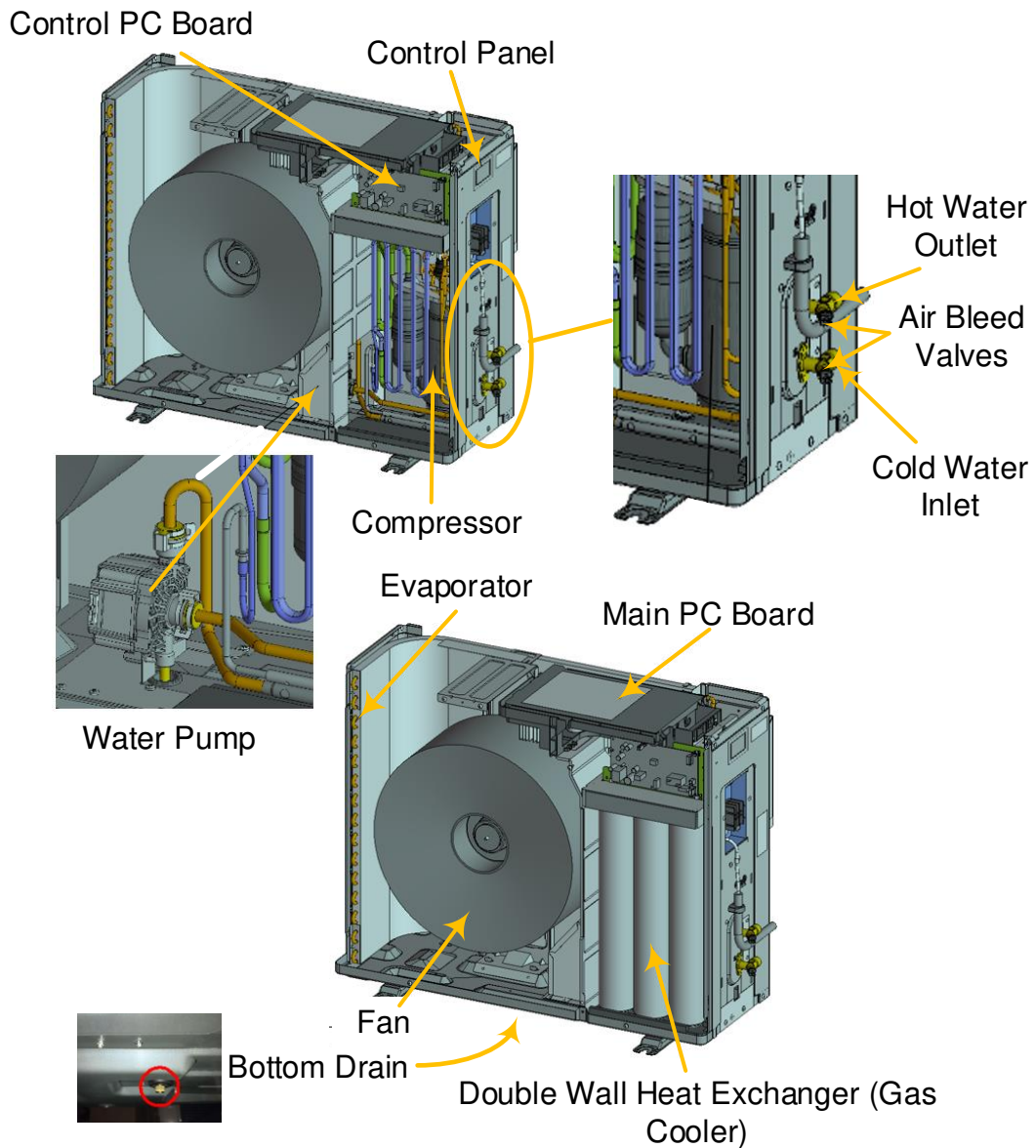

Variable Speed Fan

The fan speed is based on the ambient temperature for maximum capacity & efficiency.

Water Pump

Water flow is controlled by a variable speed water pump located inside the heat pump, the flow rate is varied to maintain the set-point supply temperature.

PCB

The PCB constantly monitors and adjusts the operation of the heat pump to maintain capacity, efficiency and reliability.

Setting/Operation Panel

Used to navigate through each setting for the heat pump unit.

Electrical Components

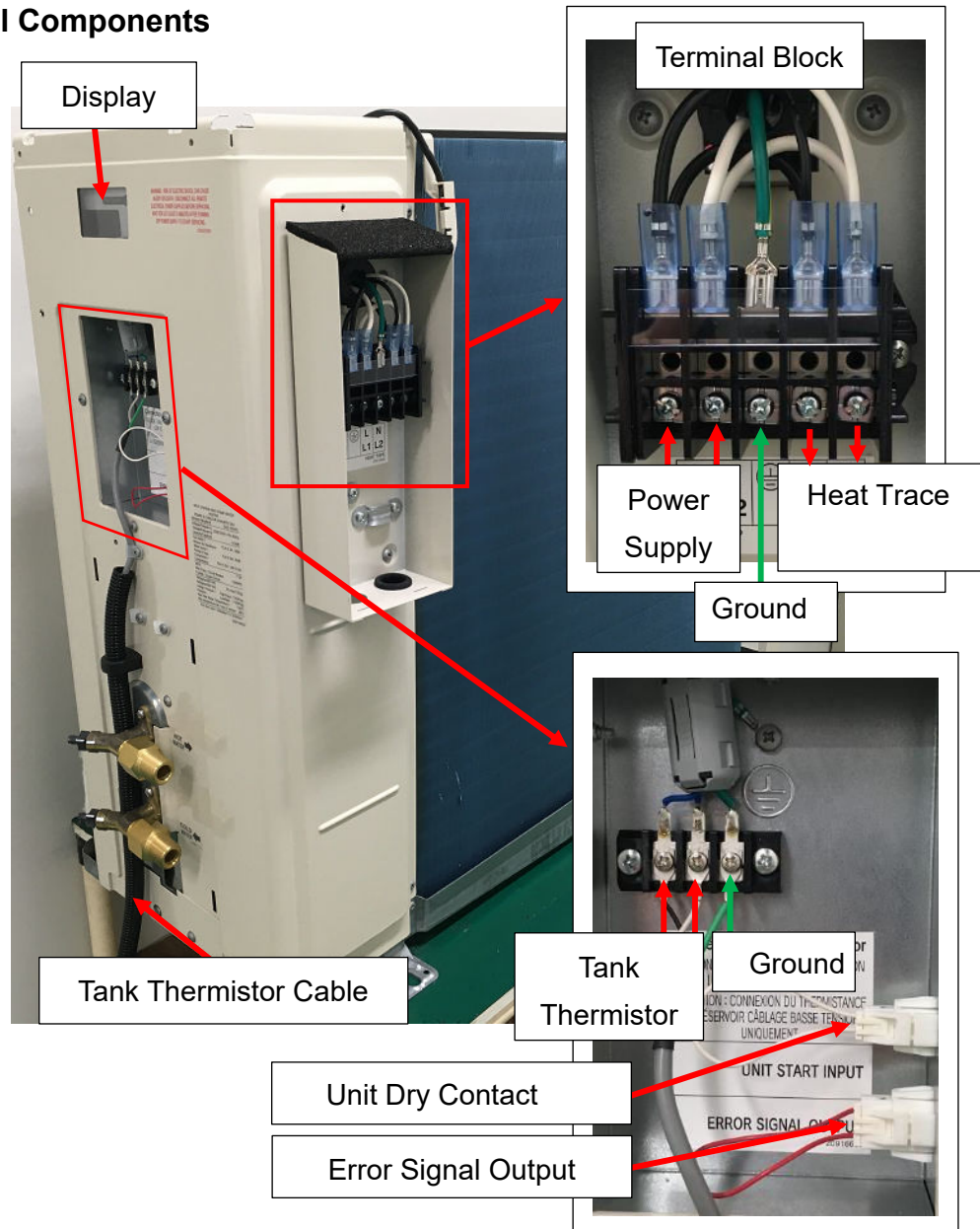

Display Panel Assembly



Panel Housing

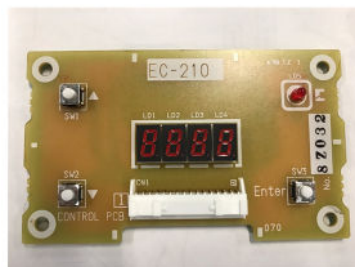

Display PCB



Heat Pump Control Modes

Setting Panel Location

The setting panel is located under the top cover and the display can be viewed through the window above the water fitting side of the heat pump and is used to navigate and select between the modes listed below.

Time Setting

As part of the water heating cycle logic refers to the current time, it is necessary to set the clock on the controller before starting to use the product.

Commissioning Mode

Press both Up/Down arrows to enter commissioning mode. Scroll through using Up arrow. Press the Enter key to select an option mode from the five modes described below.

Heat Setting Mode

Set the heating mode to either ON (unit runs) or OFF (unit cannot operate).

Block Out Time Setting

This mode is used to set a single block out time that prevents the heat pump unit operation within that chosen time period.

Error History

This records all errors that have occurred on the system and can be used for troubleshooting after an error code has been cleared by cycling the power to the unit.

Parameter Display

This displays all of the values currently measured by the unit's temperature sensors and can be used for troubleshooting and general unit performance questions.

Air Bleeding Mode

Set the Air Bleeding mode to ON. Unit runs for 5 minutes to bleed air from the inside of piping.

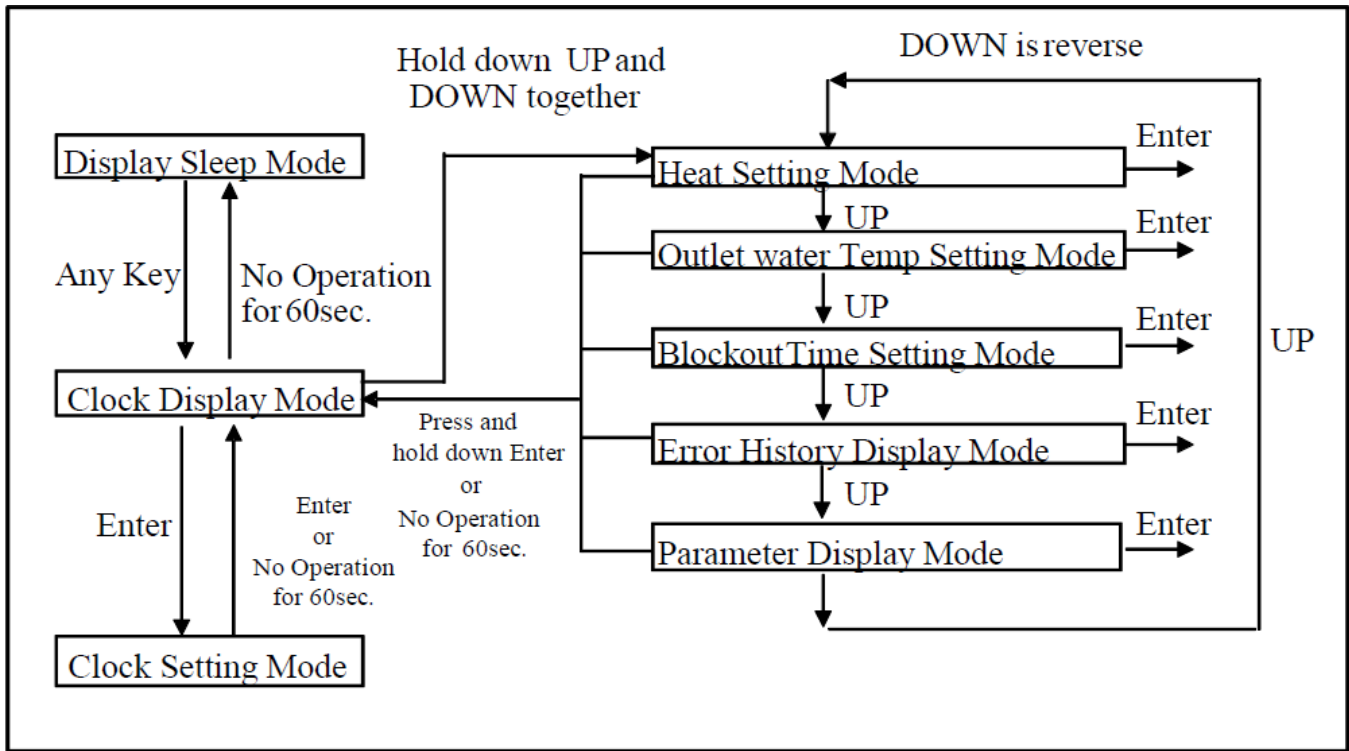

Parameters

In the parameter mode, the system will display control values used by the unit.

When a temperature value is displayed, it will shown Celsius. To convert to Fahrenheit use this formula; $^{\circ}\text{F} = (^{\circ}\text{C} \times 1.8) + 32$ Example. $80^{\circ}\text{F} = (26.7^{\circ}\text{C} \times 1.8) + 32$

(See page 35 for Celsius to Fahrenheit Chart)

Parameter	What is being measured
00	Tank Temperature °C
01	HP Outlet Water Temperature °C
02	HP Inlet Water Temperature °C
03	HP Discharge Temperature °C
04	HP Suction Temperature °C
05	HP Defrost Temperature °C
06	Ambient Temperature °C
07	Compressor Operation Frequency: Hz
08	Pump Rotation Speed: RPM
09	Fan Motor Speed: RPM
10	Compressor Operating Time: Hour
11	Compressor Start-up Count
12 to 99	Empty



Error Codes

Outdoor Unit Self Diagnosis

The outdoor unit has a built-in self-diagnostic system that will register 28 different faults based on the sensors and control logic of the outdoor unit. The control panel on the unit will display the numerical value of the error code with a red light.

All of the error codes cause the heat pump to shut down simultaneously. Error Codes are listed in the Installation and Owners Manuals provided with the unit.

Inadequate Flow

Restricted water flow to and from the heat pump will ultimately result in an error code.

If this issue arises, make sure the pipe size is correct, the pipe length/lift is inside the maximum, check the heat pump piping for blockage or kinking, look for freezing if in a cold climate, ensure all water shut off valves are open, and ensure water is supplied to the system from the building.

System Communication

A system control error show up occasionally on a heat pump unit.

- Check that all wire connections are firmly attached to the PCB.
- Check the unit for proper voltage at various points.

Clearing Errors

To clear an error code after it has been corrected, turn off power to the unit and wait 3 minutes before restarting.

The error code will now be accessible in the Error History mode on the controller.

8. Error Codes and How to deal with it

When an error has occurred, a red LED on the operation panel turns on and an error code is displayed on the LED display. The panel does not turn to the display sleep mode while the error code is shown.



After a component is replaced or the inspection is completed, turn the breaker OFF for a period of 3 minutes before restarting to confirm the error does not reoccur.

Below is the list of the error codes. If the corrective action does not solve the error problem, a malfunction of the PCB valve may be likely.

Error code	Error contents	Corrective action
H9	HP ambient (outdoor) temperature thermistor error	<ul style="list-style-type: none"> - Check the thermistor connectors on the main PCB or control PCB in the heat pump unit for any disconnect, fall-off, wire breakage or short circuit. - Measure resistance of the thermistor indicated by the error code - Replace the main PCB or control PCB
HC	HP water outlet (supply) temperature thermistor error	
J3	HP discharge temperature thermistor error	
J5	HP suction temperature thermistor error	
J6	HP defrost temperature thermistor error	
J8	HP water inlet (return) temperature thermistor error	

H7	Tank temperature thermistor error	<ul style="list-style-type: none"> - Check the thermistor cable on the terminal block in the heat pump unit for any disconnect, fall-off, wire breakage or short circuit. - Measure resistance of the thermistor - Replace the control PCB
E6	Compressor booting error	<ul style="list-style-type: none"> - Check the compressor connector. - Replace the main PCB or heat pump.
H6	Compressor revolution error	<ul style="list-style-type: none"> - Check for any piping bend, blocking, kink or frozen. - Check the water circuit is not flowing by air, dirt or scaling. - If there is air in the water, remove the air. - Check the supply voltage. - If the water circulation pump is not working, replace the pump. - Measure resistance of each thermistor. - Measure resistance of coil of expansion valve to check open or short circuit. - Replace the Reactor. - Replace the PCB or heat pump.
U0	Refrigerant leakage error	<ul style="list-style-type: none"> - Measure resistance of each thermistor. - Measure resistance of coil of expansion valve to check open or short circuit. - Replace the main PCB or heat pump.
E1	Main PCB error	<ul style="list-style-type: none"> - Replace the main PCB.
E2 L7	Control PCB error	<ul style="list-style-type: none"> - Replace the control PCB.

F5	Communication error between main PCB to control PCB	<ul style="list-style-type: none"> - Check the communication connector on the main PCB and control PCB. - Replace the main PCB or control PCB.
E8	High inlet current error	<ul style="list-style-type: none"> - Check the installation location. - Check the supply voltage. - Check for any piping bend, blocking, kink or frozen. - Check the water circuit is not flowing by air, dirt or scaling. - If there is air in the water, remove the air. - If the water circulation pump is not working, replace the pump. - Measure resistance of each thermistor. - Measure resistance of coil of expansion valve to check open or short circuit. - Replace the PCB or heat pump.
H8	Current error	<ul style="list-style-type: none"> - Replace the main PCB.
L4	High temperature of module error	<ul style="list-style-type: none"> - Check the installation location. - Remove foreign objects from the evaporator coil (e.g. fallen leaves, grass, snow) - Check the Fan motor is not flowing air due to dirt. - Replace the main PCB or fan motor.
L5	High outlet current error	<ul style="list-style-type: none"> - Measure resistance of the discharged thermistor. - Measure resistance of coil of expansion valve to check open or short circuit. - Replace the main PCB or heat pump.

P4	Module temperature thermistor error	- Replace the main PCB.
U2	High voltage error	- Check the supply voltage.
HJ	Water circuit error	<ul style="list-style-type: none"> - Check the inlet water valve. - Check for any piping bend, blocking, kink or frozen. - Check the water circuit is not flowing by air, dirt or scaling. - If there is air in the water, remove the air. - If the water circulation pump is not working, replace the pump. - Measure resistance of each thermistor. - Measure resistance of coil of expansion valve to check open or short circuit. - Replace the main PCB or heat pump.
EC	High water outlet error	<ul style="list-style-type: none"> - Check the water circuit is not flowing by air, dirt or scaling. - If there is air in the water, remove the air. - If the water circulation pump is not working, replace the pump. - Measure resistance of water outlet (Supply) thermistor. - Replace the main PCB.

E9	Water circulation pump error	<ul style="list-style-type: none"> - Check the water is full in the Tank. - Check the water circuit is not flowing by air. - If there is air in the water, remove the air. - If the water circulation pump is not working, replace the pump. - Check the RPM speed of pump by controller. If the RPM is low, replace the pump. - Replace the main PCB
E7	Fan motor locked	<ul style="list-style-type: none"> - Remove foreign objects/debris around the fan motor. - Check the fan motor connectors on the main PCB. - Replace the main PCB.
F3	Discharge temperature error	<ul style="list-style-type: none"> - Measure resistance of the discharge thermistor. - Replace the main PCB or heat pump.
H0	High water outlet error	<ul style="list-style-type: none"> - Check the water circuit is not flowing by air, dirt or scaling. - If there is air in the water, remove the air. - If the water circulation pump is not working, replace the pump. - Measure resistance of water outlet (supply) thermistor. - Replace the controller. - Replace the main PCB.

FA	High pressure side error	<ul style="list-style-type: none"> - Check for any piping bend, blocking, kink or frozen. - Check the water circuit is not flowing by air, dirt or scaling. - If there is air in the water, remove the air. - Ensure mains water supply is available. - Ensure all shut off valves are open. - If the water circulation pump is not working, replace the pump. - In areas with hard water ensure Gas Cooler is not scaled up, descale if necessary. - Replace the main PCB or heat pump.
H3	Pressure switch error	<ul style="list-style-type: none"> - Check the thermistor connectors on the main PCB or control PCB in the heat pump unit for any disconnect, fall-off, wire breakage or short circuit. - Replace the main PCB.

Troubleshooting guide

If you faced to a problem in a use of the Heat Pump Water Heater system, please check the following things prior to calling support.

Status	Considerable Causes	Action to Take
No hot water comes out of water faucet Temperature of hot water is too low	Little hot water remains in the storage tank.	Stop using hot water and wait for about 1 hour.
	Air removing procedure from the heat pump system may be insufficient.	Open the water drain plugs on the Heat pump Unit to remove air from water circuit.
	Filter on cold inlet connector may be blocked.	Check the filter and remove if there is any blockage.
	Water flow speed may be dropped due to the heat pump water piping having a bend, blockage or crush.	Check for any piping bend or crush and remove if any.
	Pipes may be frozen.	If frozen area is found on the piping, melt the ice on the pipe and provide a heat insulation.
	Stop valve is closed.	Open the valve
	Air absorption is not sufficient due to a blockage on the evaporator.	Remove the object being blocking the air flow through the evaporator (e.g. fallen leaves, grass, snow, etc.)

Caution

Do not turn off the electricity supplied to the heat pump system even if you go away from home and do not use hot water for a long period.

If the system is equipped with freeze protection heaters, also do not shut the power supply to the heaters.

Failure to do so may cause the pipes to crack due to freezing

Temperature-resistance conversion table

HP Thermistor

Inlet Water Temperature Thermistor

Temp (°F)	32	41	50	59	68	77	86	95	104	113
Temp (°C)	0	5	10	15	20	25	30	35	40	45
Resistance (kΩ)	28.94	23.07	18.49	14.95	12.21	9.98	8.25	6.87	5.73	4.81
Temp (°F)	122	131	140	150						
Temp (°C)	50	55	60	65						
Resistance (kΩ)	4.07	3.46	2.95	2.52						

Outlet Water Temperature Thermistor

Temp (°F)	32	41	50	59	68	77	86	95	104	113
Temp (°C)	0	5	10	15	20	25	30	35	40	45
Resistance (kΩ)	179.4	137.8	106.8	82.62	65.2	51.74	41.02	33.15	26.80	21.84
Temp (°F)	122	131	140	150	158	167	176	185	194	203
Temp (°C)	50	55	60	65	70	75	80	85	90	95
Resistance (kΩ)	17.9	14.81	12.26	10.24	8.56	7.23	6.13	5.20	4.44	3.82

Ambient, Suction & Defrost Temperature Thermistor

Temp (°F)	-22	-13	-4	5	14	23	32	41	50	59
Temp (°C)	-30	-25	-20	-15	-10	-5	0	5	10	15
Resistance (kΩ)	138.2	104.1	79.01	60.43	46.90	36.69	29.02	23.05	18.50	14.97
Temp (°F)	68	77	86	95	104	113				
Temp (°C)	20	25	30	35	40	45				
Resistance (kΩ)	12.22	10.01	8.26	6.84	5.72	4.81				

Discharge Temperature Thermistor

Temp (°F)	32	41	50	59	68	77	86	95	104	113
Temp (°C)	0	5	10	15	20	25	30	35	40	45
Resistance (kΩ)	173.60	134.26	102.60	81.28	64.33	51.18	40.65	32.89	26.80	21.97
Temp (°F)	122	131	140	150	158	167	176	185	194	203
Temp (°C)	50	55	60	65	70	75	80	85	90	95
Resistance (kΩ)	18.10	15.03	12.49	10.46	8.84	7.46	6.35	5.43	4.66	4.01
Temp (°F)	212	221	230	239	248					
Temp (°C)	100	105	110	115	120					
Resistance (kΩ)	3.47	3.01	2.63	2.30	2.02					

Storage Tank Temperature Thermistor

Temp (°F)	32	50	68	86	104	122	140	158	176	194
Temp (°C)	0	10	20	30	40	50	60	70	80	90
Resistance (kΩ)	32.4	19.9	12.5	8.1	5.3	3.6	2.5	1.8	1.3	0.9

GS4-45HPC System Maintenance

Split systems Heat Pump Water Heaters are very easy to maintain, in reality they are not very different to the maintenance on a Central A/C or heat pump system, so can be placed on a similar maintenance schedule.

Annually perform the following: (Maintenance frequency can be increased if the system is installed in a particularly dirty or hostile environment, e.g. Commercial Kitchen).

Heat Pump

Power wash the Heat Pump (use cold water at home pressure), remove any visible dirt or debris.

Remove the top and front cover of the unit and check the evaporator coil for any dirt or debris. On the evaporator coil, simply blow away the debris with an air hose when the covers are removed.

Spray the Evaporator coil down after the debris removal using a water hose when on the panels are reinstalled.

Evaporator coil cleaning solutions can be used without problem.

Check for leaks of any kind from Cold Water, Hot Water piping to the Heat Pump.

Ensure that pipe insulation for the piping is not torn off exposing the Water piping. Open both air bleed valves on the both the Cold Inlet and Hot Outlet piping of the Heat Pump to ensure no sediment or air pressure in the piping.

A Drain Valve air bleed is installed underneath the unit base, open the valve to ensure no sediment or air pressure.

Check for operation of the FG2-6L trace heat protection (if this option part is fitted).

The FG2-6L option will be connected to the 230V Power terminal connections to provide power to the trace heat system.

System

Draw Domestic Hot Water from the tank via a faucet.

Measure the delivered mixed water temperature versus the customer requirement. Adjust the mixing valve setting if needed to provide the required Water temperature.

Draw sufficient Hot Water from the tank to start the heat pump.

Check the unit operation to ensure delivery of the delivered water temperature to the storage tank.

If freeze protection system is responding to low ambient temperature (below 37°F or 3°C) or low Cold or Hot Water temperatures check unit operation and ensure main power is provided to the Heat Pump.

Check error history on unit controller. Note any recent or new error codes.

Continued

Tank

Check the piping for leaks of the pipe connections from the house to the Storage Tank.

Cold Water from Building supply.

Hot Water via Mixing valve to Domestic Hot Water piping to house.

Cold Water piping to the GS4-45HPC Heat Pump.

Hot Water piping from the GS4-45HPC Heat Pump to the Storage Tank.

Open the Tank pressure relief valve to prevent the valve from sticking closed, ensure water is discharged from the Tank.

Check the thermistor connection wired from the Heat Pump into the Tank thermistor well and the wiring connection to the terminals (both sides of the terminal).

Thermistor levels can be tested if required.



Warranty Information - Residential Applications

The ECO₂ warranty is 10 years on the heat pump refrigeration circuit, 10 years on all other parts, 15 years (prorated after 10 years) on the tank, and 3 years on labor costs.

Warranty support first starts with the distributing company.

Initially, they should be able to provide information on the correct application, shipping and handling procedures for the product and general installation advice.

Always check the product packaging prior to leaving the distributor, note any damage and return the product to the distributor if necessary – DO NOT install damaged units and attempt to claim as a warranty.

Should a problem occur with the product, the distributor will be the first point of contact in the warranty process. A warranty claim can be filed either online or a request for a form can be sent to info@eco2waterheater.com.

Following proper procedures will expedite warranties.

A warranty claim form should be filled out completely and will be reviewed by ECO₂ Technical Support employee. After review, the claim will be processed and filed. If it is not filled out correctly, additional time may be required to complete the information required.

If a claim is determined to be valid, ECO₂ may contact the contractor or technician to review the installation. When approved, warranty parts will be expedited.

Please complete the information on the warranty claim form as completely as possible before submitting to expedite the warranty process.

Heat pump serial numbers are CCXXXXX- The entire serial number is requested when completing a claim.

On the tank unit, the serial number is located underneath the pressure relief valve and is SWLXXXX.

Once warranty repair is complete, unless specifically requested that the part be returned, failed component can be field scrapped.

FAHRENHEIT TO CELSIUS CONVERSION CHART

°F	°C	°F	°C	°F	°C	°F	°C	°F	°C	°F	°C
1	-17.2	21	-6.1	41	5.0	61	16.1	81	27.2	101	38.3
2	-16.7	22	-5.6	42	5.6	62	16.7	82	27.8	102	38.9
3	-16.1	23	-5.0	43	6.1	63	17.2	83	28.3	103	39.4
4	-15.6	24	-4.4	44	6.7	64	17.8	84	28.9	104	40.0
5	-15.0	25	-3.9	45	7.2	65	18.3	85	29.4	105	40.6
6	-14.4	26	-3.3	46	7.8	66	18.9	86	30.0	106	41.1
7	-13.9	27	-2.8	47	8.3	67	19.4	87	30.6	107	41.7
8	-13.3	28	-2.2	48	8.9	68	20.0	88	31.1	108	42.2
9	-12.8	29	-1.7	49	9.4	69	20.6	89	31.7	109	42.8
10	-12.2	30	-1.1	50	10.0	70	21.1	90	32.2	110	43.3
11	-11.7	31	-0.6	51	10.6	71	21.7	91	32.8	111	43.9
12	-11.1	32	0.0	52	11.1	72	22.2	92	33.3	112	44.4
13	-10.6	33	0.6	53	11.7	73	22.8	93	33.9	113	45.0
14	-10.0	34	1.1	54	12.2	74	23.3	94	34.4	114	45.6
15	-9.4	35	1.7	55	12.8	75	23.9	95	35.0	115	46.1
16	-8.9	36	2.2	56	13.3	76	24.4	96	35.6	116	46.7
17	-8.3	37	2.8	57	13.9	77	25.0	97	36.1	117	47.2
18	-7.8	38	3.3	58	14.4	78	25.6	98	36.7	118	47.8
19	-7.2	39	3.9	59	15.0	79	26.1	99	37.2	119	48.3
20	-6.7	40	4.4	60	15.6	80	26.7	100	37.8	120	48.9

CELSIUS TO FAHRENHEIT CONVERSION CHART

°C	°F	°C	°F	°C	°F	°C	°F	°C	°F	°C	°F
-17.0	1.4	-6.0	21.2	5.0	41.0	16.0	60.8	27.0	80.6	38.0	100.4
-16.5	2.3	-5.5	22.1	5.5	41.9	16.5	61.7	27.5	81.5	38.5	101.3
-16.0	3.2	-5.0	23.0	6.0	42.8	17.0	62.6	28.0	82.4	39.0	102.2
-15.5	4.1	-4.5	23.9	6.5	43.7	17.5	63.5	28.5	83.3	39.5	103.1
-15.0	5.0	-4.0	24.8	7.0	44.6	18.0	64.4	29.0	84.2	40.0	104.0
-14.5	5.9	-3.5	25.7	7.5	45.5	18.5	65.3	29.5	85.1	40.5	104.9
-14.0	6.8	-3.0	26.6	8.0	46.4	19.0	66.2	30.0	86.0	41.0	105.8
-13.5	7.7	-2.5	27.5	8.5	47.3	19.5	67.1	30.5	86.9	41.5	106.7
-13.0	8.6	-2.0	28.4	9.0	48.2	20.0	68.0	31.0	87.8	42.0	107.6
-12.5	9.5	-1.5	29.3	9.5	49.1	20.5	68.9	31.5	88.7	42.5	108.5
-12.0	10.4	-1.0	30.2	10.0	50.0	21.0	69.8	32.0	89.6	43.0	109.4
-11.5	11.3	-0.5	31.1	10.5	50.9	21.5	70.7	32.5	90.5	43.5	110.3
-11.0	12.2	0.0	32.0	11.0	51.8	22.0	71.6	33.0	91.4	44.0	111.2
-10.5	13.1	0.5	32.9	11.5	52.7	22.5	72.5	33.5	92.3	44.5	112.1
-10.0	14.0	1.0	33.8	12.0	53.6	23.0	73.4	34.0	93.2	45.0	113.0
-9.5	14.9	1.5	34.7	12.5	54.5	23.5	74.3	34.5	94.1	45.5	113.9
-9.0	15.8	2.0	35.6	13.0	55.4	24.0	75.2	35.0	95.0	46.0	114.8
-8.5	16.7	2.5	36.5	13.5	56.3	24.5	76.1	35.5	95.9	46.5	115.7
-8.0	17.6	3.0	37.4	14.0	57.2	25.0	77.0	36.0	96.8	47.0	116.6
-7.5	18.5	3.5	38.3	14.5	58.1	25.5	77.9	36.5	97.7	47.5	117.5
-7.0	19.4	4.0	39.2	15.0	59.0	26.0	78.8	37.0	98.6	48.0	118.4
-6.5	20.3	4.5	40.1	15.5	59.9	26.5	79.7	37.5	99.5	48.5	119.3



Glossary

Uniform Energy Factor

A water heater's energy efficiency is determined by the energy factor (UEF), which is based on the amount of hot water produced per unit of energy consumed over a typical day. The higher the energy factor, the more efficient the water heater.

First Hour Rating

First Hour Delivery (or sometimes called first hour rating) is a term that describes the performance capability of the water heater. By definition, first hour delivery is the calculated amount of hot water that fully contained storage tank can deliver in the first hour period. It does not mean the hot water will last for one full hour depending on previous hot water usage through the day.

Storage Tank	Capacity	UEF	First Hour Rating
Model	Gallons		(FHR)
SAN-43SSAQA	43	3.10	69 Gallons
SAN-83SSAQA	83	3.75	115 Gallons
SAN-119GLBK	119	3.40	135 Gallons

Commercial Storage Tanks

Model	Gallons	Recovery per HP @ 90°F rise	Capacity per HP
ECO-200GLNST	200	20.5 GPH	4.5 kW or 15,400 btu/hr.
ECO-285GLNST	285	20.5 GPH	*4.5 kw or 15,400 btu/hr.
ECO-455GLNST	455	20.5 GPH	*4.5 kw or 15,400 btu/hr.
ECO-505GLNST	505	20.5 GPH	*4.5 kw or 15,400 btu/hr.

*SANCO₂ HPWH GS4-45HPC



Manual Notes

Thank you for reading this manual, we hope it has been informative.

Please note that all ECO₂ units are subject to continuous improvement and specifications can change without notice.

Always check the information supplied with the unit before installation.

All sizing guides contained in this manual are suggestions only, based on our experience and knowledge, please perform an accurate DHW load analysis prior to selecting and installing your SANCO₂ system

We hope you enjoy the hot water produced from your SANCO₂ unit.

John and Maho