



SANDEN

Delivering Excellence



Owner's manual

Sanden Heat Pump Water Heater with Natural Refrigerant (CO2)

Covering model numbers for residence

Heat Pump Unit GS3-45HPA-US



This appliance is not to be installed by unqualified and unlicensed persons, please read and understand this manual prior to installing and operating the unit.

Contents

Contents.....	2
Introduction	3
How it works.....	3
Installation details.....	7
Trouble shooting guide	8
Error Codes.....	9
Filling the System & Purging Air	10
Mains Power/Electrical Installation	11
Electrical connections.....	11
How to connect Main Power	11
System operation using continuous power	12
System operation if connected to Demand Response power.....	13
Water Supply Quality (Supplemental).....	14
Change of water supply.....	14
Technical data	15
Warranty Policy	18
Registration for warranty	23

PATENTS

This water heater may be protected by one or more patents or registered designs in the name of Sanden International (USA), Inc.

TRADE MARKS

® Registered trademark of Sanden International (USA), Inc.

Note: Every care has been taken to ensure accuracy in preparation of this publication.

No liability can be accepted for any consequences that may arise as a result of its application. Sanden is in a process of continuous improvement with, therefore specifications may be different to those referenced in this manual – Please contact Sanden International or it's distributors for the latest specifications at the time of install.

Introduction

The Sanden Sanco₂ Heat Pump Water Heater System has been designed using the latest refrigeration technology to remove the heat from the air to heat water. The refrigerant used is CO₂ which does not contribute to global warming so it allows us to help keep a clean healthy earth for future generations.

We have also considered the power requirement. By using CO₂ as the refrigerant, we have produced one of the most energy efficient units currently available. It is even more efficient when connected to demand response power and the noise level is so low it will operate unobtrusively throughout the night.

How it works

The Sanden Sanco₂ Heat Pump Water Heater System heats water by transferring the heat from the surrounding air to the water using a refrigerant. The refrigerant is heated by a heat exchanger that absorbs heat from the surrounding air (Figure 1).

Figure 1: Heat Pump Water Heater System

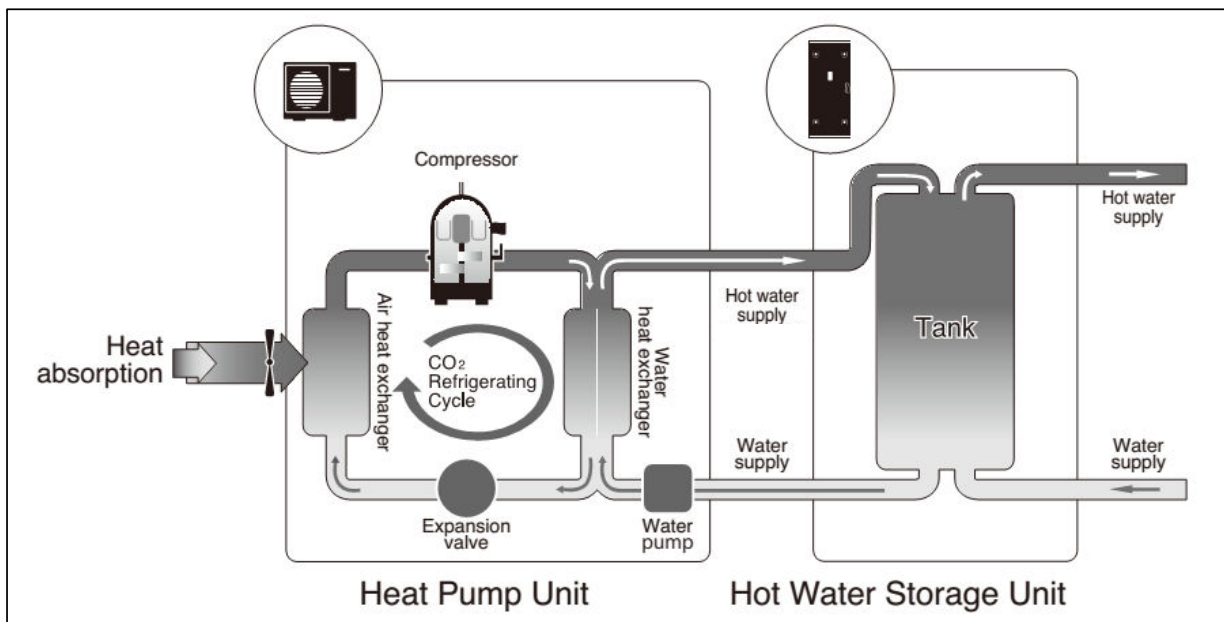

Note:



The unit must have a minimum of 5 hours continuous power available at all time to allow the unit to operate without affecting reliability.

Safety precautions







Please ensure you fully observe the precautions.

The following instructions need to be fully followed to prevent any harm to users and others or damage to your property.

■ The extent of the possible harm or damage caused by misuse of the product falls into the following classifications.



 Warning	The column with this classification indicates “the extent of harm that includes the possibility of death or serious injury”.
 Caution	The column with this classification indicates “the extent of harm/damage that includes the possibility of injury or damage to property”.

■ The type of content to be observed can be explained with the following pictorial classifications.

	Indicates content requiring “attention”.
  	Indicates content that is prohibited.
 	Indicates content with “instructions” that need to be fully followed.

Warning

Do not touch the faucet while hot water is being supplied

Do not touch

Could result in being burnt by hot water.

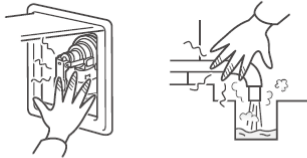

Do not touch the relief valve, drainage pipe, drain outlet or drain elbow when inspecting the relief valve or while draining hot water.

Do not touch

Could result in being burnt by hot water.

Check the water temperature before supplying any hot water or taking a shower.

Could result in being burnt.

Do not touch the heat pump unit pipes or hot-water supply pipes.

Could result in being burnt.

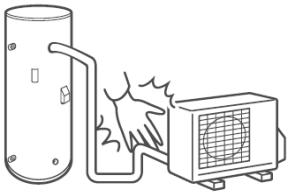
Warning

Do not use any damaged, altered, or bundled power cords.

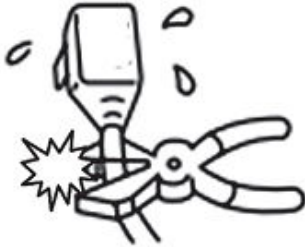

Verify that the piping has all been insulated.

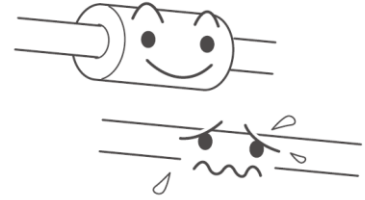

Any of the pipes freezing up and getting damaged could result in scalding or water leaking.

· Please contact the dealer on insulating the pipes.

Ensure the product is removed from any gas containers, sources of fire and flammable substances.

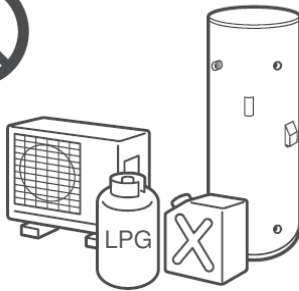

Sparks from the electrical parts of the product could result in fire.

Do not disassemble, repair or alter the product in any way.



Do not disassemble

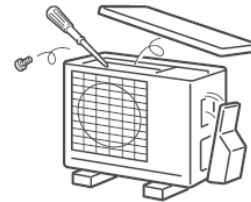

Could result in electric shock or fire.

· Contact the dealer for repair.

Do not open the front board of the hot water storage unit or the heat pump unit cover.



Do not disassemble

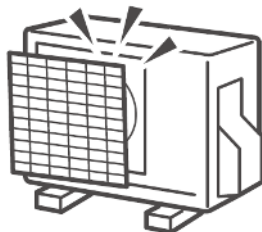

Could result in electric shock.

Do not poke your fingers or a stick into the air inlet (fins)/air outlet of the heat pump unit.



Attention – Rotating object

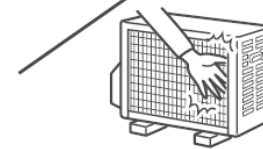
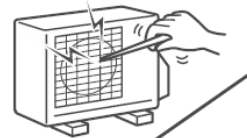

Could result in injury.

⚠ Caution

Do not climb or put anything on top of the unit. Do not apply any force to the piping.

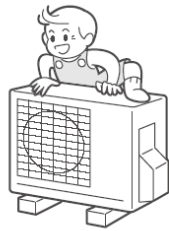

Could result in injuries from a fall or being scalded.

Do not use the heat pump unit if the installation blocks have been damaged.

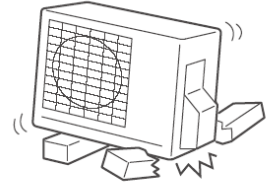

Damaged installation blocks could result in the heat pump unit falling over and causing injury.

Do not put anything susceptible to humidity under the heat pump unit.

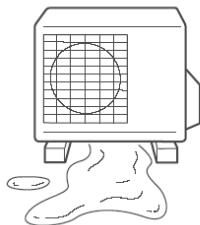

Water could drain out. In addition, condensation could drip from the pipe connections.

Ensure no animal or plant life is placed directly in front of where air is blown from the unit.

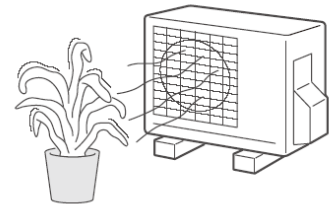

Could result in harm to animal and plant life.

Do not block the air inlet and outlet.

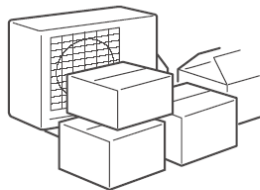

Could harmfully influence performance and lead to failure.

Remove any snow from the units after snowfalls.



Snow building up around the heat pump unit and hot water storage tank unit could result in malfunction and failure.

Select an installation place with consideration given to neighbors.

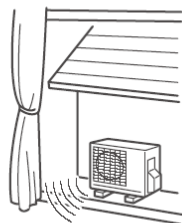

Please select a place where noise and vibration while operating will not bother your neighbors.

Check the installation conditions of the unit.

Installation of the unit in the following places could result in accidents or failure and the performance of the unit not being guaranteed.

- Anywhere the lowest temperature reached is under minus 4 degree Fahrenheit
- Indoors (Applies only to the heat pump unit)
- Anywhere not completely flat, unstable or where drainage is difficult
- Ensure not to put anything around the heat pump unit. Could result in poor performance and unexpected problems. In the winter in particular please pay attention to any snow coverage.

Installation details

This Sanden Eco Hot water Heat Pump System must be installed by licensed personnel in accordance with local building codes:

- Installing contractor should be licensed by applicable state/province and municipal authorities to install an Electrical & Plumbing product.
- The unit has been designed for heating potable domestic hot water and any other usage, such as space heating requires a heat exchanger suitable for local codes to be installed on the system to separate potable and non-potable water.
- The unit is designed to operate when connected to the water supply with a maximum operating pressure of 95PSI (655 kPa). To ensure the mains pressure does not exceed this, first check incoming cold water mains pressure, and then a pressure regulating device must be connected to the water supply line.
-  **DANGER** This system delivers hot water exceeding 120 °F (50 °C). Installation of a temperature tempering device is **MANDATORY** to avoid potential scalds and burns.
- The unit must be stored and transported in an upright position. Failure to do so may render the unit faulty. Such failure is not covered under any warranty agreements.

Failure to comply with the above conditions will void the warranty.

Trouble shooting guide

If you face a problem while using our Heat Pump water heater system, please check the following table prior to calling for support.

Status	Considerable Causes	Action to Take
No hot water comes out of water tap Temperature of hot water is too low	Small or no hot water is left in the storage tank.	<ul style="list-style-type: none"> - Stop using hot water and wait for about 1 hour - Consider a change of the electricity supply off-peak mode (Length of power-supply hours may be too short for the water heating cycle to cover the hot water consumption)
	Air removing procedure from the heat pump system may be insufficient.	- Open the water drain plugs on the Heat Pump Unit to remove air from water circuit. (Be careful for burning)
	Filter on cold inlet connector may be blocked.	- Check the filter and remove if there is any blockage
	Water flow speed may be dropped due to the heat pump piping bend, blockage or crush.	- Check for any piping bend or crush and remove if any
	Pipes may be frozen.	- If frozen area is found on the piping, melt the ice on the pipe and provide a heat insulation
	Stop valve is closed.	- Open the valve
	Air absorption is not sufficient due to a blockage on the evaporator.	-Remove the object blocking the air flow through the evaporator (e.g. fallen leaves, grass, snow, etc.)

For those problems not listed above, an inspection provided by a skilled engineer is required. Please contact the distributor.

Caution:

Do not shut the electricity supplied to the Heat Pump system off even if you go away from home and do not use hot water for a long while.

If the system is equipped with freeze protect heaters, also do not shut the power supply to the heaters.

Failure to do so may cause a crack on the pipes due to the pipes getting frozen.

Error Codes

When an error has occurred, a red LED on the operation panel turns on and an error code is displayed on the LED display. The panel does not turn to the display sleep mode while the error code is shown.

Figure 3 Error Code example



Below is the list of the error codes. If the corrective action does not solve the error problem, a malfunction of the PCB is highly likely.

Error code	Error contents	Error code	Error contents
E001	HP water outlet over temperature 1	E015	HP ambient temperature thermistor wire break
E002	HP water outlet over temperature 2	E016	Tank thermistor wire break
E003	HP outlet temperature thermistor detection error	E021	HP inlet temperature thermistor wire short circuit
E004	HP discharge over temperature 1	E022	HP outlet temperature thermistor wire short circuit
E005	HP discharge over temperature 2	E023	HP discharge temperature thermistor wire short circuit
E006	HP discharge temperature Thermistor detection error	E024	HP defrost temperature thermistor wire short circuit
E007	High pressure side error	E025	HP ambient temperature thermistor wire short circuit
E008	High ambient temperature defrost drive error	E026	Tank thermistor short circuit
E009	HP defrost thermistor detection error	E031	Fan motor locked
E011	HP inlet temperature thermistor wire break	E032	Fan motor revolution error
E012	HP outlet temperature thermistor wire break	E034	Water circulation pump locked
E013	HP discharge temperature thermistor wire break	E040 ~ E082	System control error
E014	HP defrost temperature thermistor wire break		

Filling the System & Purging Air

The following steps must be taken to ensure all air is removed from the system. Incorrect purging of air may cause the water temperature to vary during operation.

- Ensure that all piping to tank unit and heat pump unit are installed and connections are tight, then open the Cold Water Supply Valve to the system.
- Push up the lever on the PR valve to open, and fill the tank unit with water. Confirm that water comes out of the relief valve, and then close the lever.
- Open the hot water faucets to remove air from the house piping system.
- Close the faucets after no air is seen in the water.
- Open the water drain plugs (two places) on the heat pump unit. Close the plugs after no air is seen in the water.
- Supply power to the heat pump unit and leave the hot water faucets open for 3 minutes. Close the faucet after no air can be seen in the water.

Figure 4: Air removal process

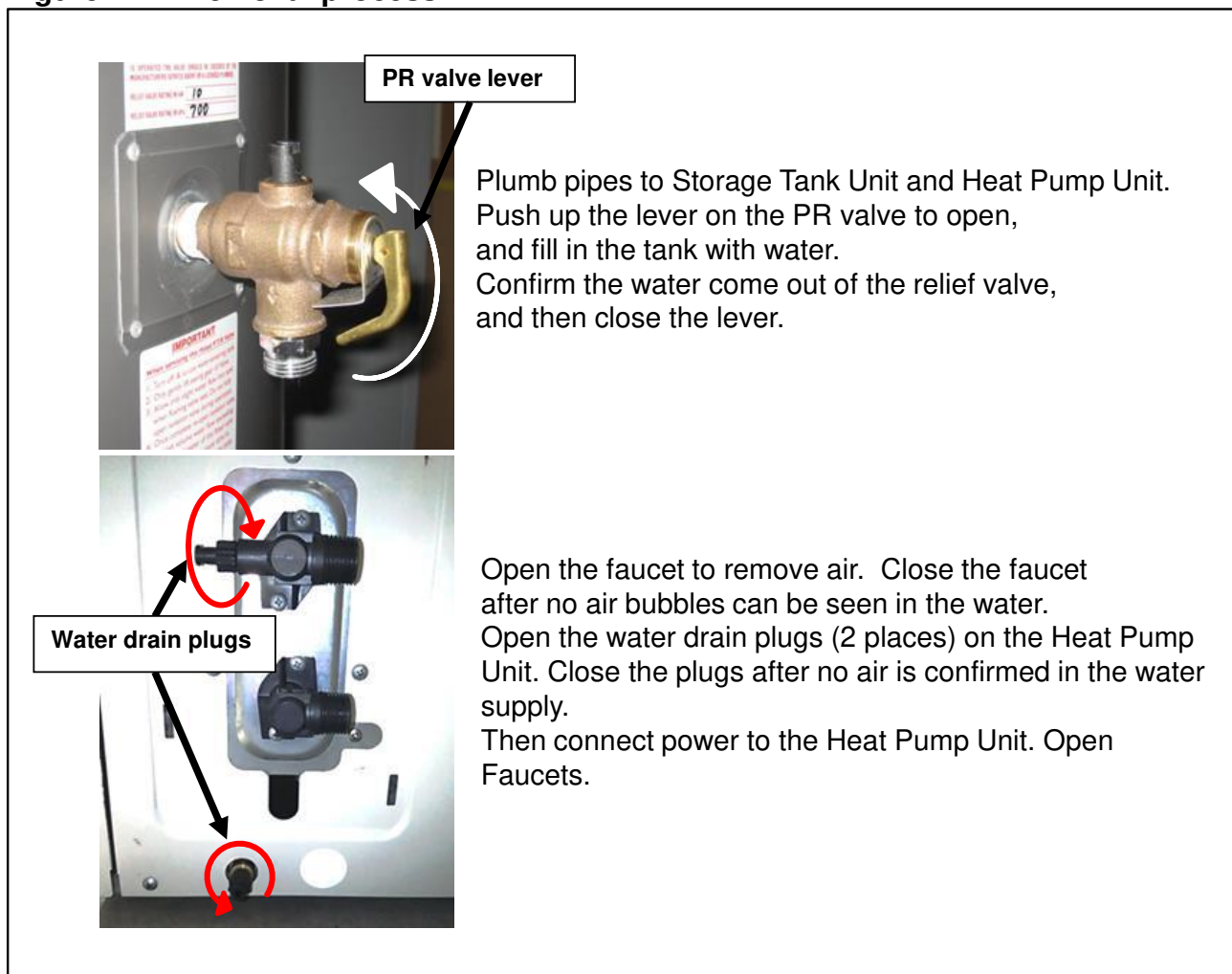

Mains Power/Electrical Installation

DANGER

- All Electrical Wiring should be done in accordance with the latest edition of the National Electrical Code (NEC) and all local State/Province and Municipality codes.
- The power requirement for the system is a dedicated 15 amp circuit fitted with a circuit breaker. This circuit may be connected to constant power or off-peak power.
- A local disconnect should be installed adjacent to the Heat Pump unit in accordance to NEC and local codes.
- Installation of this system must be carried out only by a qualified installation technician (electrical or plumbing).

Electrical connections

Electrical installation should only be done by a licensed electrician
Outline of electrical system connections

- Breaker size and wiring must be sized per NEC rules for the rating plate amperage, MCA and MOP or Max Circuit Breaker.
- **Power Supply is 208/230V-1Ph-60Hz**
- **Verify that the tank unit is full of water and the water shut off valves are open before turning on the power.**

How to connect Main Power

- Remove the terminal block cover (Philips head screwdriver required)
- Connect the power wiring to the terminal block per the wiring diagram/manual.
- Ensure ground wire is connected.
- Secure the power supply wiring below the terminal block with the screw clamp fitting.
- Attach the terminal block cover and piping cover back on the heat pump unit.

Figure 5: Power connection

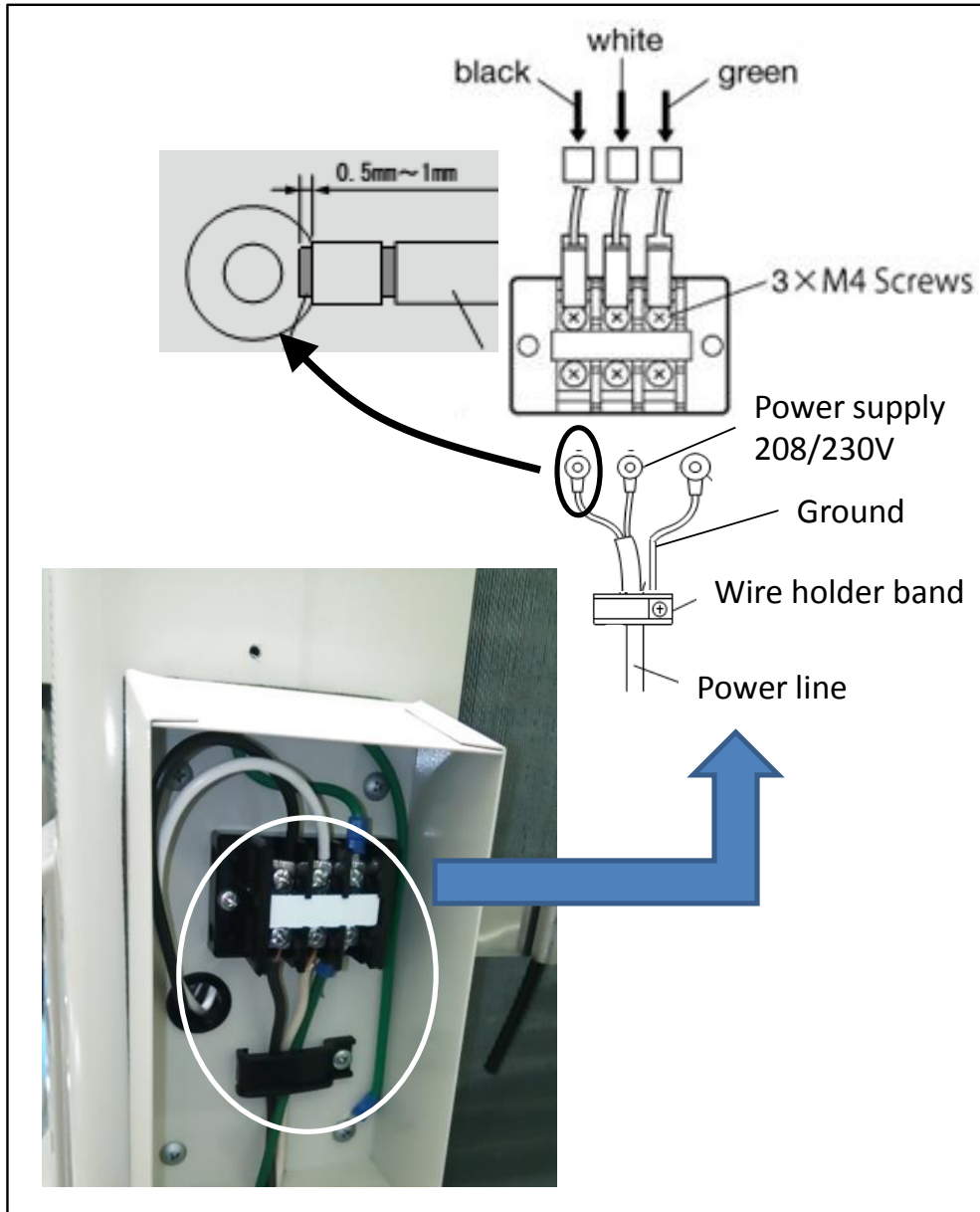

System operation using continuous power

- The system runs its water heating cycle once a day to fill up the storage tank unit with heated water.
- If the block out time function is selected the unit will not operate during the block out times – this function is typically used on installations that have time of use electricity tariffs.
- The water heating cycle operation starts automatically when the residual hot water in the tank unit is less than 40 gallons (150 litres).
- The system will not run if the electrical power supply is cut off (i.e. if it is connected to demand response power). However, the system will automatically start operation, once the electric power is restored.

System operation if connected to Demand Response power

- There are no special settings for the Demand Response. The system will run once power becomes available and the temperature in the tank drops below the set point of the tank thermistor.
- If connecting the unit to Demand Response power, ensure that the off peak tariff provides a minimum of 5 hours continuous power, as it can take at least four hours to fill the tank unit with hot water.
If the ambient temperature is lower than 50°F (10°C) this can be longer.
- If the unit is connected to Demand Response power and hot water consumption has been higher than normal, hot water might not be available until the next power supply cycle.
- Daily frequency and amount of hot water consumption may also affect the duration of the heating cycle operation.

Select the electrical supply mode that best suits the customer's hot water consumption. The type of off-peak connection may need to be changed if hot water supply is not maintained as required.

Figure 6: Outline of electrical system connections

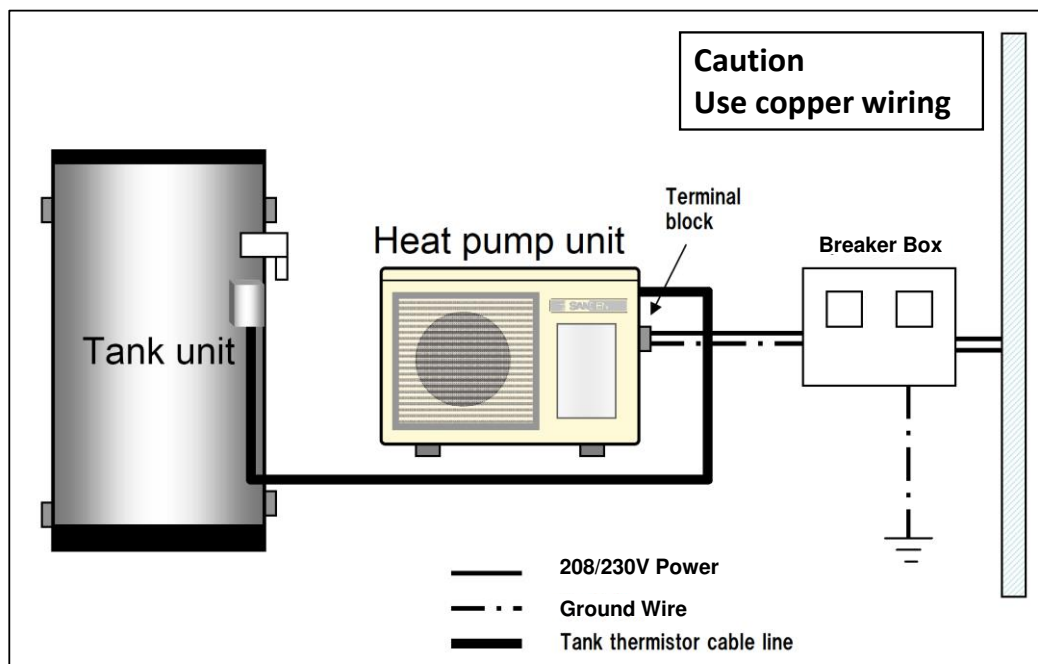

The basic system installation is now complete; the unit is now ready for initial filling, air purge and then start up.

Check the Installation against the Installation Check list provided at the end of this manual

Ensure that the work site is tidy; Sanden International recommends the use of Slim Duct or Fortress product to cover water piping on the outside of the house

Water Supply Quality (Supplemental)

Chloride and PH

In areas with a high concentration of chloride in the water, that water can cause corrosion and subsequent failures. Where the chloride level exceeds 0.1 ounces per gallons (200 mg/litre), the warranty is no longer valid on to the heat pump unit and tank unit.

PH is a measure of whether the water is alkaline or acid. In an acidic water supply, the water can attack the parts and cause them to fail.

No warranty coverage is given on the heat pump unit and tank unit where the PH is less than 6.0.

Supply Water with a PH less than 6.0 may be treated to raise the PH. It is recommended that an analysis of the Supply Water be conducted before connecting the Heat pump unit to the system.

Figure 7 Chlorides and PH

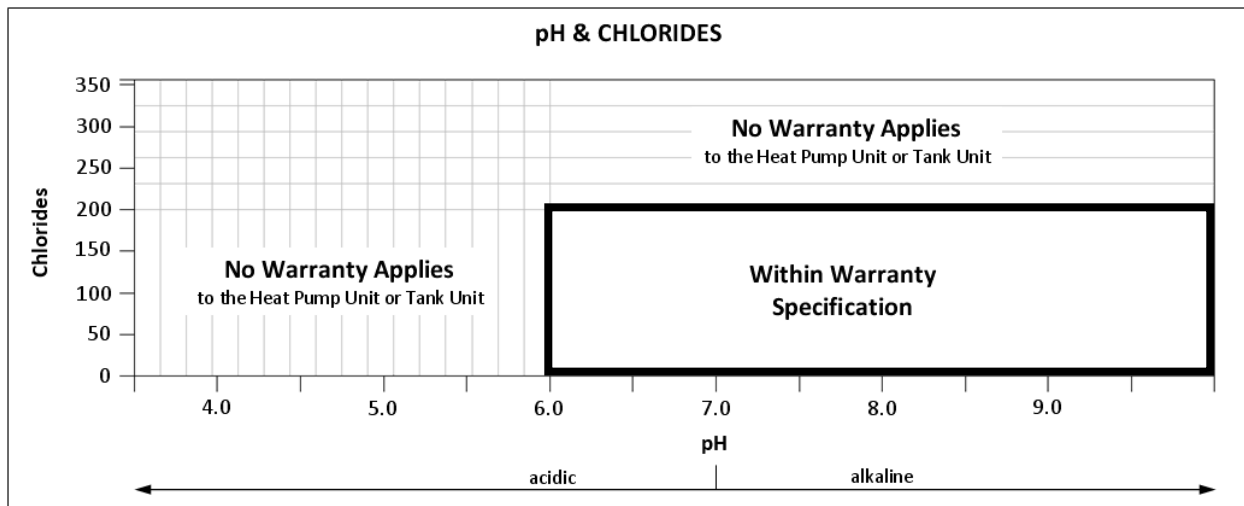

Change of water supply

Changing, or alternating, from one water supply to another can have a detrimental effect on the operation and/or life expectation of the water tank unit cylinder, PR valve, water heating circulation and the heat exchanger in the system.

Where there is a changeover from one water supply to another, for example, a rainwater tank supply, desalinated water supply, public recirculated water supply or water brought in from another supply, then water chemistry information should be sought from the supplier or the water should be tested to ensure it meets the warranty requirements in this installation manual.

Technical data

Hot water storage tank unit

Material information

Storage tank material	Stainless steel
Outside casing	Colour coated zinc steel

Stainless Steel Storage Tank Dimensions

Stainless Steel Storage Tank

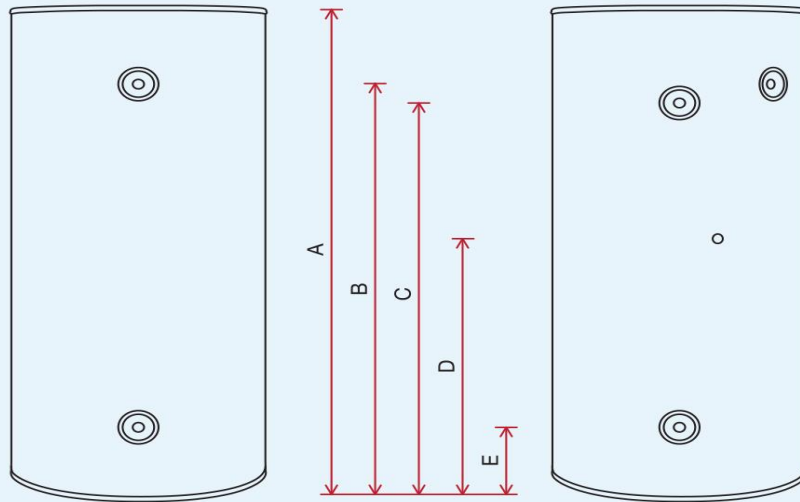
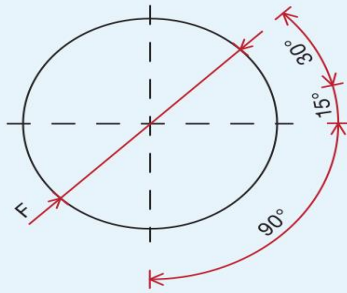

Tank Model No:	GAUS-160QTA	GAUS-315EQTD	SAN-43SSAQA	SAN-83SSAQA
A Height	47- ¹ / ₄ "	58- ⁵ / ₈ "	38- ¹ / ₈ "	68- ⁷ / ₈ "
B Hot Water Outlet & PR Valve	37- ³ / ₈ "	49- ⁵ / ₈ "	29- ¹ / ₂ "	60- ¹ / ₄ "
C Heat Pump Return	37- ³ / ₈ "	49- ⁵ / ₈ "	29- ¹ / ₂ "	60- ¹ / ₄ "
D Sensor Port	17- ¹ / ₈ "	37"	9- ³ / ₄ "	40 ³ / ₈ "
E Cold Water Inlet / Cold Water to HP	8- ¹ / ₄ "	7- ⁷ / ₈ "	8- ³ / ₄ "	8- ³ / ₄ "
F Diameter	22- ¹ / ₂ "	26- ³ / ₄ "	24- ¹ / ₂ "	24- ¹ / ₂ "
Weight (lbs)	88 lbs	154 lbs	88 lbs	115 lbs
Tank Capacity (gallons)	43 gallons	83 gallons	43 gallons	83 gallons

Connection Sizes

Cold Water Inlet	³ / ₄ " NPT
Hot Water Outlet	³ / ₄ " NPT
Cold Water to Heat Pump	³ / ₄ " NPT
Hot Water Return from Heat Pump	³ / ₄ " NPT
Pressure Relief Valve Setting (Psig)	125 Psig

Note: Materials and specifications are subject to change without notice.

REV 1216

GS3-45HPA-US Dimensions

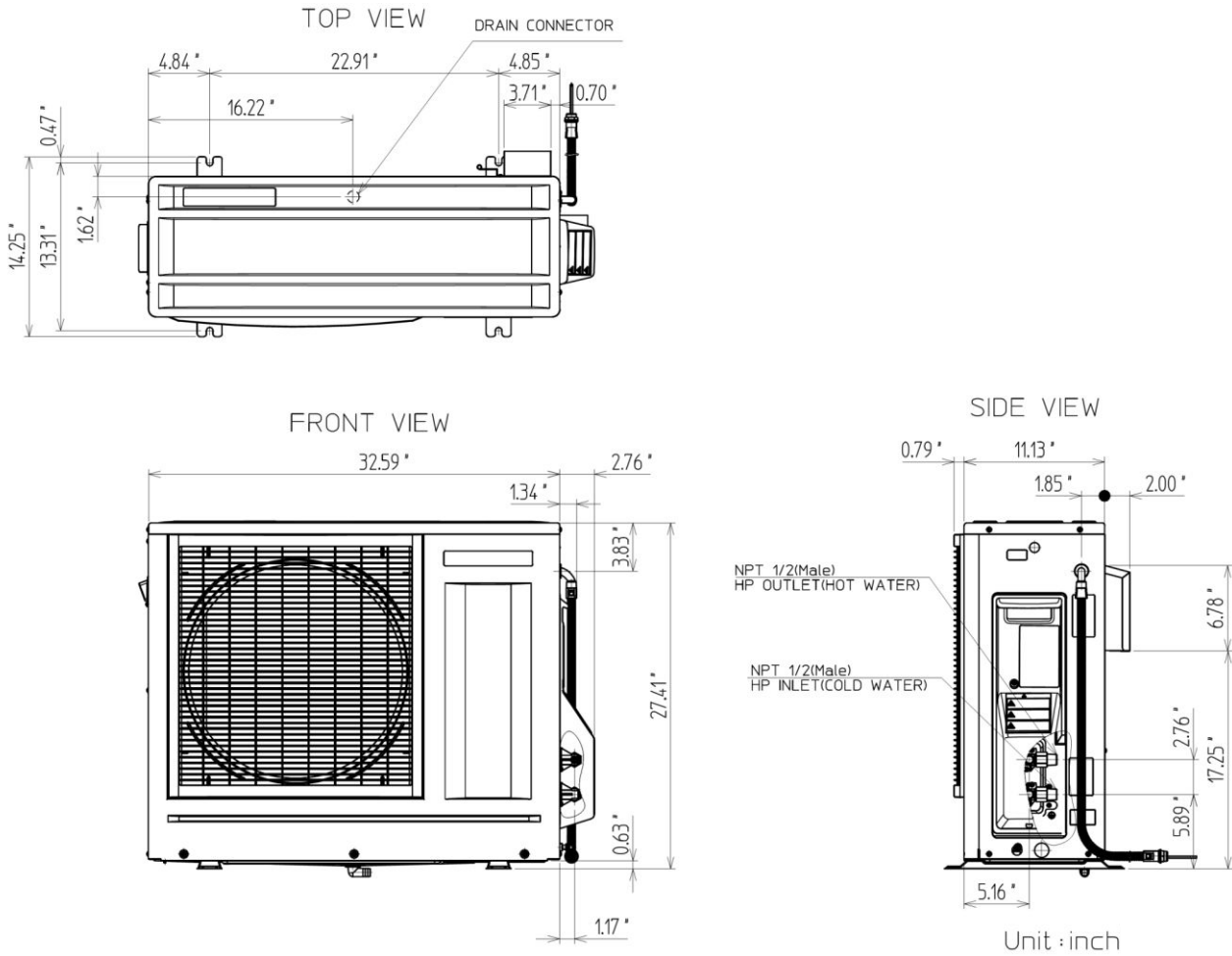

Specification

Refrigerant type	R744(CO2)
Mass volume	22 oz. (650g)
Setting Outlet water temp	130~175° F
Product weight	106lb (48 kg)
Thermal capacity	4.5 kw
Fan motor FLA	0.3A , 70W
Water pump FLA	0.2A , 30W
Compressor RLA / LRA	7.5 / 9.8A
MCA	13A
Circuit Breaker Size	15A
Design Pressure(High / Low)	1885 /1059 PSI
Max inlet water temperature	110° F
Protection Raining Class	IPX4
Max, Operating water Pressure	700kPa

Warranty Policy

Covering the following Model #'s :

Heat Pump : GS3-45HPA, GUS-A45HPA

Storage Tanks : SAN-43SSAQA, SAN-83SSAQA, SAN-119GLBK, GAUS-160QTA & GAUS-315EQTD

Warranty Conditions as of April 1 2019 to the Original Owner Only

1. Warranty period

Subject to the Warranty Conditions and Exclusions stated below, the Sanden Heat Pump Water Heater System with the corresponding model numbers warranted in Residential / Combi DHW & Heating applications as follows:

1-1. Residential DHW application ; Heat pump unit

Sanden warrants all parts & labor on the SANCO₂ system for a period of 3 years from date of installation and a further 7 years on Parts only excluding shipping costs.

Labor costs are paid per the payment cost schedule published by Sanden and revised from time to time at Sanden's requirement (Exhibit A).

Should at any time during the 10 year Parts warranty any component directly part of the CO₂ refrigerant circuit fail, where replacement of that component would require opening of the refrigerant circuit, Sanden will replace the Heat Pump unit in it's entirety. If this failure occurs in the first 3 years of operation then Labor costs will be paid per Exhibit A.

1-2. Residential DHW application ; Tank unit

Sanden warrants that the *SAN-43SSAQA, SAN-83SSAQA, GAUS-160QTA, GAUS-315EQTD* tanks will be free from defects for 10 years at 100% replacement, and for a further 5 years under a pro-rated scale, culminating in warranty ending after Fifteen years from date of installation.

Failure in Year 11:	80% of replacement value
Failure in Year 12:	60% of replacement value
Failure in Year 13:	40% of replacement value
Failure in Year 14:	20% of replacement value

SAN-119GLBK tanks have a warranty of 10 years only at 100% replacement value.

1-3. Combined DHW/Heating application

When used in a Combined DHW/Heating System application providing that the winter design (99%) temperature must be above 22°F and with a single heat pump unit serving a heating load of less than 10,000 Btu/h in addition to a minimum DHW demand of 20 Gallons per day then the warranty period will be amended to that stated below.

1-3.1. Combined DHW/Heating application ; Heat pump unit

Sanden warrants all parts & labor on the SANCO2 combi system for a period of 2 years from date of installation and a further 5 years on Parts only excluding shipping costs. Labor costs are paid per the payment cost schedule published by Sanden and revised from time to time at Sanden's requirement.

1-3.2. Combined DHW/Heating application ; Tank unit

The Storage tank warranty period is unaffected by the usage in a Combined DHW/Heating system and remains unchanged from the warranty period stated previously.

2. Warranty Conditions

- 2-1. The Sanden Heat Pump Water Heater System must be installed in accordance with the installation instructions supplied with the Heat Pump Water Heater System, all relevant industry practices and in accordance with all relevant plumbing codes plus statutory/local requirements of the state/province/municipality of the location where the water heater is installed.
- 2-2. Where a failed component or Heat Pump Water Heater System is replaced under warranty, the balance of the original warranty period will remain effective. The replaced part or complete new Heat Pump Water Heater System does not carry a new warranty.
- 2-3. Warranty period only applies from the verified date of system installation, if such a date cannot be verified then the warranty will be deemed to have started using a date calculated after 2 (two) months have elapsed from the date of unit manufacture.
- 2-4. Where the Heat Pump Water Heater System is installed in a position that does not allow safe operating practices, such as not installing a properly size metal drain pan if installed in an area where leakage from the tank or it's connections would result in damage to the area adjacent to the heat pump or the storage tank.

- 2-5. The cost of accessing the site safely, including the cost of additional materials handling and/or safety equipment, shall be the owner's responsibility.
- 2-6. The warranty only applies to the Heat Pump Water Heater System (heat pump & storage tank) and original or genuine (company) component replacement parts and therefore does not cover any plumbing or electrical parts supplied by the installer and not an integral part of the Heat Pump Water Heater System. Such parts would include but not limited to; pressure regulating valves, isolation valves, solenoid valves, electrical switches, pumps, trace heating, fuses or any other field supplied parts used in the installation of the Sanden Heat Pump Water Heater system.
- 2-7. The Heat Pump Water Heater System must be sized to the hot water demand in accordance with the guidelines in the current Sanden Heat Pump Water Heater System literature and application guides and training information.
- 2-8. This warranty is for parts only, any and all labor costs associated with diagnosis, removal of the faulty part and installation of replacement parts will solely be the owner's responsibility except where covered by the labor warranty section of this warranty.

3. Warranty Exclusions

Repair and replacement work will be carried out as set out in the Sanden Heat Pump Water Heater System warranty. However the following exclusions may void the warranty and may incur additional service charges and/or cost of parts:

- 3-1. Accidental damage to the Heat Pump Water Heater System or any component, including: Acts of God, failure due to misuse, incorrect installation, attempts to repair the water heater other than by a Sanden accredited service agent or the Sanden service department.

- 3-2. On inspection of the failed system or part, and where it is found there is nothing wrong with the Heat Pump Water Heater System; where the complaint is related to excessive discharge from the temperature and/or the pressure relief valve due to high incoming cold water pressure over 75 Psi; where there is no flow of hot water due to faulty plumbing; where water leaks are related to plumbing and not the Heat Pump Water Heater System or its components; where there is a failure of electricity or water supplies; where the supply of electricity or water does not comply with relevant codes or acts or is of the incorrect voltage, phase and amperage as required by the system; Installation of the GS3-45HPA and GUS-A45HPA heat pump(s) with other storage tanks that have not been specifically approved in writing by Sanden Eco Systems.
- 3-3. Where the Heat Pump Water Heater System or its component has failed directly or indirectly as a result of excessive water pressure above 75 Psi.
- 3-4. The factory supplied pressure regulating drain valve or an ASME approved valve with the same pressure specification has not been installed or the valve outlet is blocked or corroded.
- 3-5. Where the heat pump or storage tank has rusted or failed as a result of a corrosive atmosphere.
- 3-6. Where the unit fails to operate or fails as a result of ice formation in the piping to or from the Heat Pump Water Heater System. Suitably sized self-regulating trace heating must be installed around the exposed supply and return piping to and from the heat pump including around the unit connections whenever the Heat Pump unit is installed in a location where the winter ambient temperature will fall below 27°F.
- 3-7. Where the Heat Pump Water Heater System is located in a position that does not comply with the Heat Pump Water Heater System installation instructions or relevant statutory requirements, causing the need for major dismantling or removal of cupboards, doors or walls, or use of special equipment to move the unit to floor or ground level or to a serviceable position.
- 3-8. Repair and/or replacement of the Heat Pump Water Heater System due to scale

formation above 200ppm (water hardness) in the waterways or the effects of either corrosive water or water with a high chloride or low PH level when the water heater has been connected to a scaling or corrosive water supply or a water supply with a high chloride or low PH level as outlined in the *Owner's Guide* and *Installation Manual*.

- 3-9. Replacement due to cosmetic reasons, or for reasons of noise, taste, odor; discolored and/or rusty water.
- 3-10. Failure of a Combined DHW/Heat System where the Heating application has been used to provide "construction heat" in an unoccupied unfinished, unfurnished building for the purposes of heating the structure so that other building trades or building processes can be completed.
- 3-11. Internet purchase: Any Sanden Heat Pump Water Heater Systems that are purchased on the internet are not eligible for warranty. The system must be purchased from a Sanden certified distributor/contractor and installed by a licensed plumbing/HVAC contractor.

Subject to any statutory provisions to the contrary, this warranty specifically excludes any and all claims for damage to furniture, carpets, walls, foundations, personal property or any other consequential loss either directly or indirectly due to leakage from the Heat Pump Water Heater System, or due to leakage from fittings and/or pipe work of metal, plastic or other materials caused by water temperature, poor workmanship or other modes of failure. Sanden shall not be liable by virtue of this warranty or otherwise for damage to any persons or property, whether direct or indirect, and whether arising in contract or in tort.

This warranty gives you specific legal rights, and you may have other rights which vary under the laws of each state. If any provision of this warranty is prohibited or invalid under applicable state law, that provision shall be deemed to be ineffective to the extent of the prohibition or invalidity, but without invalidating the remainder of the affected provision or the other provisions of the warranty.

The publication of this warranty document supersedes all other warranty documents in place as of 4-1-2019.

Exhibit A: Labor Costs

Labor costs are paid per the payment cost schedule published by Sanden and revised from

time to time at Sanden's requirement.

Labor warranty specifically excludes (unless agreed prior to service being carried out) costs associated with travel to and from jobsites, distributors or contractors place of business, initial fault diagnosis and subsequent work due to incorrect diagnosis of fault or additional faults due to poor replacement practice of the failed part, delivery costs associated with replacement parts or units, or any other such administrative costs. These costs are to be the responsibility of the owner.

Labor expense reimbursement by part or action (USD) as of 4/1/2019

i. PCB replacement	\$100
ii. Thermistor replacement	\$75
iii. Controller replacement	\$75
iv. Fan motor replacement	\$75
v. Pump replacement	\$100
vi. Expansion valve coil replacement	\$75
vii. Other miscellaneous component replacement	\$100
viii. Fan blade replacement	\$75
ix. Complete unit replacement (Heat Pump or Tank)	\$210

Registration for warranty

In order to register your system for warranty purposes, please complete the details of your purchase below, detach and mail to

Sanden International USA Inc.
47772 Halyard Dr. Plymouth, MI 48170

Name _____
Mailing address _____ State _____
Postcode _____
Product Details:
Heat Pump Serial Number (from label on right end) _____
Hot Water Tank Serial Number (label on tank) _____
Date of Purchase/Installation ____/____/20____
Suppliers Name _____

You may register your product via email, to '<http://www.sanden.com/>'. Simply send an email containing the same details as shown above

Please Note: Similar registration details will be provided to Sanden by your supplier/installer to validate their claim for warranty support; it is essential that the dates of supply/installation correspond to within one month.

SANDEN HEAT PUMP
40950-44672 Owner's Manual US