



SUBMITTAL : GS5-45HPC-D & ECO-119GLBB 119 Gallon Tank



Job Name	Location
Purchaser	Engineer
Submitted to	Reference <input type="checkbox"/> Approval <input type="checkbox"/> Construction <input type="checkbox"/>
Unit Designation	Schedule #

Specifications	GS5-45HPC-D
Performance	
Uniform Energy Factor	3.72
Uniform First Hour Rating	134 Gallons
Nom Heating Capacity (Btu/h)	15,400 Btu/h
Nom Heating Capacity (kw)	4.5kw
Heating COP @ 80/47/17°F	5.5 / 4.2 / 2.8
Water Temperature Setting (°F)	145°F or 150°F
Refrigerant Type	R744 (CO ₂)
Refrigerant Charge (Oz)	25.4oz (720g)
Power Voltage	208/230v-1Ph-60Hz
Breaker Size	15A
MCA (Amps)	7.2A
Compressor MRC (Amps)	5.0A
Fan Motor MOC/Watts	0.3A / 30W
Pump MOC/Watts	0.6A / 60W
Drain Pan Heater MOC/Watts	0.6A / 132W
Noise Level (DbA)	37
Weight (lbs)	110lbs
Storage Tank	
ECO-119GLBB	
Nominal Volume	119 Gallons
Pressure Relief Valve (Psig & °F)	150 & 210°F
Temperature Sensor	Thermistor
Tank Weight (lbs)	345lbs
Standby Loss in 67°F Ambient	107 Btu/h
Tank Connection Sizes	
Cold Water Inlet	1 1/2" NPT
Hot Water Outlet	1 1/2" NPT
Cold Water to Heat Pump	3/4" NPT
Hot Water Return from HP	3/4" NPT
Pipe Size - Tank to Heat Pump	
Cold Water pipe - Tank to HP	1/2"
Hot Water pipe - HP to Tank	1/2"
Max Pipe Length inc	66ft
Max Vertical Separation of	23ft
Certifications	
Safety	ETL & ETLc
Performance	Energy Star
Warranty - System	
Heat Pump	3 Years Labor
Tank	10 Years Parts
	10 Years

Construction

The Outdoor unit shall be galvanized steel with a baked on powder coated finish on all panels except for unit base

Heat Exchangers

Evaporator coil shall be mechanically bonded Aluminum fin to copper tube. Fins shall be coated to resist corrosion

The Refrigerant to Water HX (Gas Cooler) shall be a Double Wall type pressure tested to 6000 psi

Refrigerant System

Compressor shall be a hermetically sealed DC Inverter drive Rotary vane type
Refrigerant shall be R744 (CO₂).

Refrigerant flow shall be controlled by EEV

Fan & Motor

The outdoor unit fan shall be a propeller type, driven by a BLDC Motor

Water Pump

The pump shall be a BLDC Impellor type

Controls

The unit shall be operated using a temperature sensor mounted in the Storage tank

Control wiring shall require 18-2AWG shielded wire
Ambient operating range shall be -25°F to 114°F

A Modbus communication signal shall be accepted by the GS5 Heat Pump via a Controller that shall be supplied by ECO2 Systems as an accessory

Storage Tank

Storage tank shall be constructed from mild steel with a baked on Colbalt enriched porcelain lining
Storage Tank connections shall be NPT. Storage Tank shall be supplied with Mixing Valve & PTR Valve

Interconnect Piping

Interconnect Piping shall be 1/2" copper or where permitted 1/2" PEX tubing

Both Cold and Hot piping should be insulated with min 3/4" closed cell foam and where required Heat Trace tape shall be used to prevent pipes from freezing



SUBMITTAL : GS5-45HPC-D & ECO-119GLBB 119 Gallon Tank



Job Name	Location		
Purchaser	Engineer		
Submitted to	Reference <input type="checkbox"/>	Approval <input type="checkbox"/>	Construction <input type="checkbox"/>
Unit Designation	Schedule #		

GS5-45HPC-D Dimensions

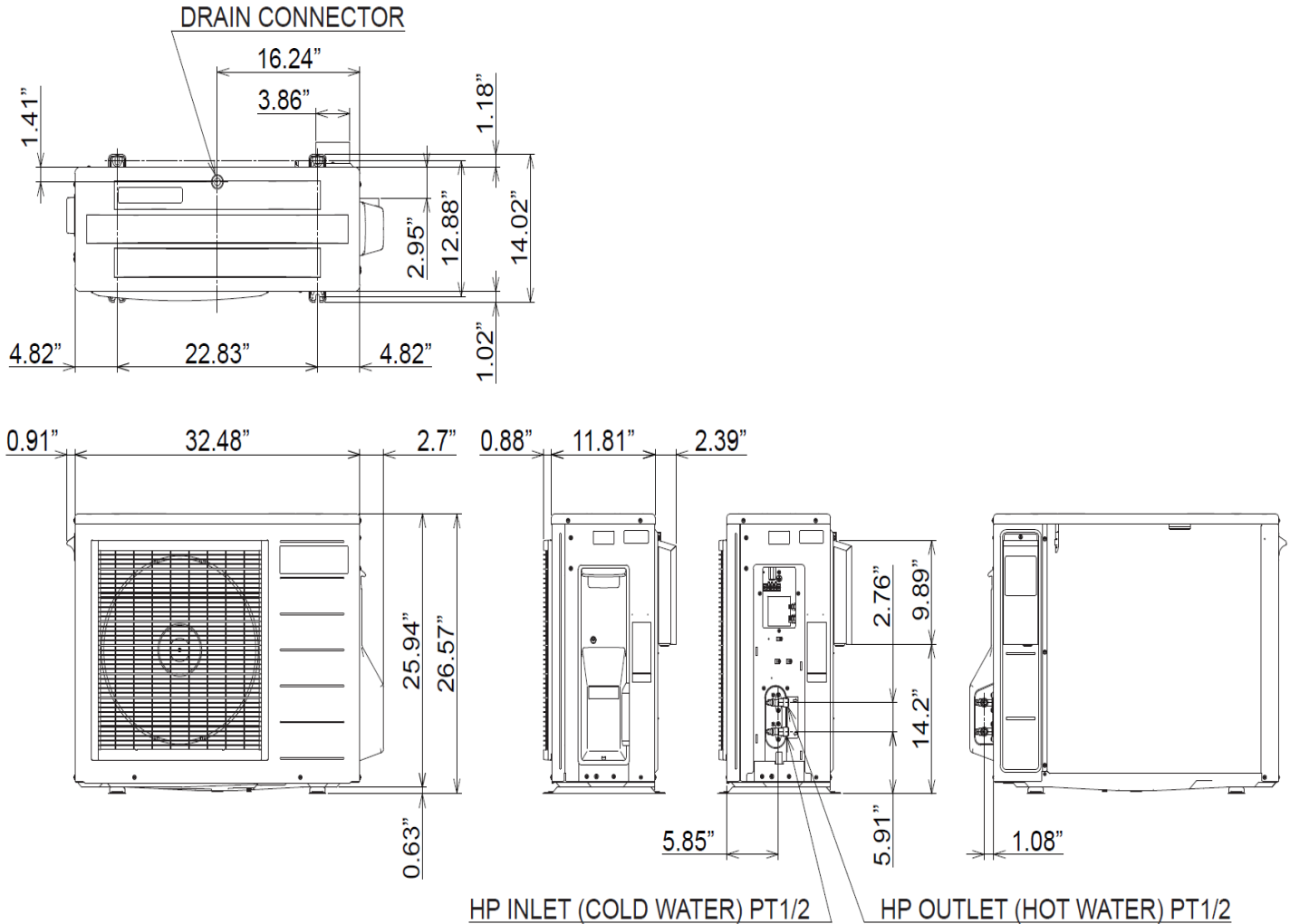

Unit: inch



SUBMITTAL : GS5-45HPC-D & ECO-119GLBB 119 Gallon Tank



Job Name	Location		
Purchaser	Engineer		
Submitted to	Reference <input type="checkbox"/>	Approval <input type="checkbox"/>	Construction <input type="checkbox"/>
Unit Designation	Schedule #		

ECO-119GLBB Glass Lined Storage Tank Dimensions

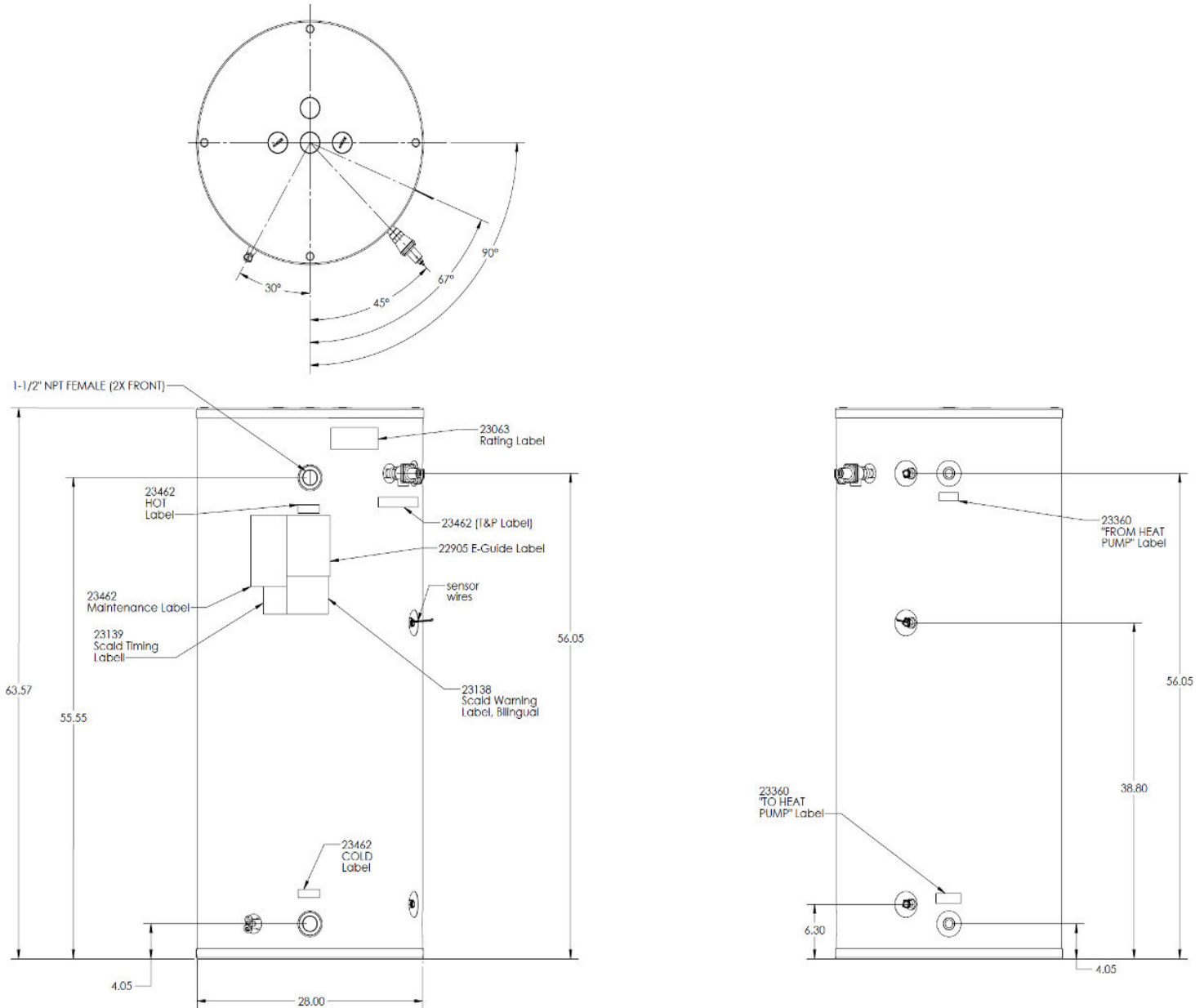

Eco2 Systems LLC

PO Box 1358, Walled Lake MI 48390, Tel : 1-844 SAND CO2 (1-844 726 3262)

www.eco2waterheater.com

Due to Eco2 Systems LLC's policy of on-going product development specifications are subject to change without notice

SUB-ECO2-GS5-D+119-012025

© 2025 Eco2 Systems LLC